



The Mountain GAZETTE

©Copyright 2002, Train Mountain Railroad Museum

An Official Members Only Publication of the Train Mountain Railroad Museum Issue: #14 October 2002

Sorry for the lateness of this issue. The gremlins and goblins 'crept' into my computer and well you know how the rest of the story goes. I 'think' all is now working and so here is your very late October issue!

BOO! Now that I have that out of the way let's get down to business shall we! After the hustle and bustle of the summer activities at Train Mountain one would expect a certain let down as things 'quiet down'. Well guess again fellow members. Your editor and the locals have been quite busy since the 'end of the season'. We've had a couple of weddings on the property and the Cox family was behind them all! Great fun, great weather, and we even squeezed in a couple of train rides for the guests! Train Mountain provided the facility for the 2nd Annual fund raiser for the local community center. Last year they raised over \$6,000, well this year they raised over \$11,000. WOW! Guess what the biggest ticket item was? Give up? It was the quilt created by our local ladies and the ladies of Train Mountain. \$1,335 dollars was raised on that one single item. Congratulations to all. Oh by the way, we ran trains then too! And finally we get down to the First Annual Train Mountain Fly-In! That's right a Fly-In! Evil Mark persuaded some of his flying buddies to come and spend the weekend in Chiloquin (they must be desperate, they all came!). We had lots of train rides, a great BBQ, and from what others tell me, we had a great party too! So you see things have not been too quiet yet!

Planning, planning, planning. I hope you folks are doing some planning so you can attend the 'big one' next year. We all are. Make sure in your plans you take a look at some of the other attractions that are in this area. You also need to be aware of the two different rambles that are being planned before and after the 'big one'. Almost every track in the west is scheduled to be open during the week or two before and after the 'big one'. I will be posting the schedule here as it becomes confirmed. Many of the local establishments are already getting filled up with your reservations so don't wait until the last minute. The other thing you won't want to be late about is registration. Remember in 2000 we had the sliding scale, the longer you waited the more it cost. 2003 is based on the same type of sliding scale. I have been asked why does Quentin charge for the meet? The registration sliding scale is not intended to be the source of revenue for this event, although to put on an event of this magnitude is not cheap. The sliding scale is to help in the

logistics and planning of the event. If we know in January we are going to have 1,500 people we can react and plan accordingly, if we don't know until the week before the event we are going to have 1,500 people, we are in a lot of trouble. The sooner we know the better the plan. Hence the sliding scale. Let's see how many porta-pottys per 100 people, and what about the

Planning also means that the head of the volunteers, Mark Flitton, will be very busy this winter. Check out his new column on the Triennial Preparations for further bulletins.

Making it's debut this month will be the first installment for the ladies and their 'block of the month' quilt. It will of course be a train quilt and Linda has already started mine and it's really looking great. If you guys don't care to see what the ladies are up to just skip the end of page 5 through 7 and you will be spared. For the rest of you the pattern is inserted in The Gazette at half size. For you to use it, it must be enlarged to make a 12 inch block. Check it out by going to For The Ladies,.

Carol wants to make sure you are all aware of the new email addresses for Train Mountain and staff. They are as follows:

Office (Carol) - info@trainmountain.org
Ross Perrin, (General Manager)- tmrrgm@trainmountain.org
Mr. Breen (the boss) - qlb@trainmountain.org

Table of Contents

From The Manager	2
Triennial Preparations	2
Next Work Week	3
Right of Way	3
Current Year	4
Major Project Status	4
TrackShop	4
What Works!	4
Prototype	4
The Park Grounds	4
Featured Product	4
Rules of the Road	5
Operations	5
For the Ladies	5



(Continued on page 2)

FROM THE MANAGER

The latest information for the May 2002 Meet

From the Manager:

It has been over a month since the last meet and everyone has gone home. It is so quiet around here. Even with two weddings, a dinner and auction and Evil Mark's Fly-In, it still seems quiet by comparison.

Everyone here is getting a jump on all the winterizing that is necessary and beginning winter projects. Jerry in the Back Shop is busy building Andrews Trucks. Louis has finished planting grass and is on his way to sunny Arizona. Debra has been preparing the planting beds for winter. Richard is working hard at getting all of his outdoor projects done before winter. Paul is organizing and making repairs at the Track Shop. Mark is rebuilding wood tie switches into plastic tie switches. Dick and Boyer have been felling dead trees and turning them into interesting loads for the log train. Both Sonya and Sarah were married, in separate Train Mountain ceremonies. Carol has been so hard at it, that she had to take a week's vacation.

As most of you are aware, planning for the future has become much of my workday in the last couple years. Part of this is making Train Mountain a people friendly place. And, part is complying with the various governmental requirements relating to use and zoning.

Most recently, my compliance tasks have been increased by responses required by anonymous complaints by a disgruntled ex-member. Last year it was to the Department of Environmental Quality for things such as not having a barrel labeled "Used Oil" for our used oil. Last month, it was to the Klamath County Planning Department for things like not having building permits for cabooses that have not been remodeled. This week, it was to the State Fire Marshall for things like not having a map of the room on the banquet room wall showing where the exits are.

For the most part, we are dealing with allegations that are 10% real, 20% possible, 30% wishful thinking and 50% fantasy. They are the products of a sick mind. Yet, in a weird sort of way, it is helping us to prepare for filing our Destination Resort application.

We have our Department of Environmental Quality inspection behind us and can now say with confidence that we are in full compliance with all requirements. We now know our ex-member's 22 planning complaints (including the traps he set for us when he told us his electrical work did not require permits) and can fix whatever needs to be fixed prior to filing for Destination Resort status. And, we now have our state Fire Marshall inspection behind us and have a list of exactly what we need to do to be in full compliance.

We still have our regular Conditional Use Permit review coming up in November. Without doubt, it is complicated by the 22 allegations of our ex-member. But we hope to make progress in all of the areas required to move Train Mountain forward.

Thanks to all of you that take the time to send me your suggestions and answer my questions. Not only is it good to hear from you but also the ideas are very helpful. We must be doing something right, as there were only 2 suggestions in the box from this past meet.

For those that like pictures, we will have some fall shots on the Web Site soon. Douglas Meadow is bursting into its Fall Costume.

Talk to you soon.

Ross

Ross Perrin, (General Manager)- tmrrgm@trainmountain.org

TRIENNIAL PREPARATIONS

The latest information for the Triennial

Hello all! Since the September meet at TM I have been busy. I completed a large addition to my shop for train storage, new unloading area and steaming bays, hosted a family reunion, and most importantly celebrated the marriage of our daughter last Saturday. These are the excuses I am hiding behind to justify being late in submitting this article to Russ.

NOW LETS TALK ABOUT THE 2003 TRIENNIAL!

I have been assigned the position I held at the 2000 Meet. I am the Volunteer Coordinator. Basically I will function as the meet director working with the various committee heads, TM personnel, volunteers, quests, answering questions, solving problems, helping with staffing, conducting meetings, etc.. At the end of this article will be a preliminary list of the chairpersons of various committees. I hope to have this list complete by next month. The chairpersons will be coordinating the volunteers for their area of responsibility. In the future we will publish contact information and a brief description of each committee so you can start submitting your names as volunteers. The following are answers to some of your questions:

1. We will have a meeting each morning of the work week leading up to the Triennial meet to answer questions, listen to suggestions, assign volunteers to committees, coordinate work assignments, etc.
2. Volunteers can sign up to work on more than one committee.
3. Clubs are encouraged to be involved as a group or as individuals on various committees.
4. Contact information for various chairpersons will be published in future articles.
5. Descriptions of the work involved if you volunteer for a specific committee will be explained in future articles.
6. Yes, this is a nine day meet and we will need lots of volunteers.
7. Yes, you can email me if you have an idea or question. mflitton@msn.com

(Continued on page 3)

8. We are not going to have a banquet this year but are planning for a number of food vendors on site.

9. We are hoping to have tours of caboose ridge this time so visitors can have a chance to enjoy the spectacular views and the large collection of prototype equipment.

I will answer questions each month in my allotted space in the Gazette, and provide updates on how the planning is progressing.

In closing I would like to commend Russ Wood for the outstanding newsletter he puts together each month. Ross and all the staff for making each meet run so smoothly. To Quentin, thanks for having us over to your place to play. Sharon, thanks for taking such good care of Quentin. Carol, get ready this is going to be a really big meet.

Thanks all!

Mark Flitton mflitton@msn.com

Train Mountain Triennial 2003 Preliminary Volunteer Chairperson List (10-25-02)

Chief Volunteer: Mark Flitton

Registration: Jim & Wendy Kincaid (co-chairman to be announced)

First Aid: To be announced

Unloading: Dennis Weaver (Kitsap Club)

Boiler Test: Cal Tinkham & Ted Carter

Turntable: Ed Ackerman (co-chairman to be announced)

Train Inspection: To be announced

Shuttle Vans: Rich Ledyard & Fred Vertel

Shuttle Trains: Walter Freihube, Lee Pirtle & Bob McMillan

Information Booth: Russ & Linda Wood (Center of Dealer Pavilion)

Fuel Yard: To be announced

Communications: Jim Haas & Mike Moran

Campground Hosts: Hugo & Jeanne Meisser (we will need hosts for the Six Acre and South Meadow)

Roving Track Repair: Jeff Phillips, Art Crisp, Charles "Bill" Schubert

Security: To be announced

Yard Masters: Joel Slagg & Jim Lane (Main Yard)
Dale & Veronica Taylor (Passenger station)

Photographers: Jeff Flitton (Jeff will need help)

Gardeners: To be announced (Work with Deborah)

Trash Pickup: To be announced

Back Shop Repairs: Al Witcombe, Paul Garin

NEXT WORK WEEK

What do we do next!

Tune up, fix up, spruce up, whatever you want to call it, that's what we need to do next. Our big project for 2003 is of course the Triennial meet. To put on such a meet requires that everything we currently have installed is in its proper working order. We have 13.42 miles of mainline track with over 600 switches to tune up, fix up, and spruce up. Please give us a hand at accomplishing these tasks. Also remember to plan enough time to have **fun** while you are here!

Meet	Work Week	Run	Days
May 2003	First	Sat May 24	Thu May 29 -Sun Jun 1
June 2003	Triennial	Sat June 14	Sat Jun 21 -Sun Jun 29

A special note about the Triennial schedule, there is a work week just before the Triennial June 14—20, for all those last minute, clean up, finish up, set up kinds of things. Come early and get a good spot to park, it will be lots of fun in the sun!

May Work Week Projects **May 24th--June 1st, 2003**

Tune Up, Fix Up, Spruce Up, Clean Up, Weed, Clean, etc.

Possible July Work Week Projects **July 26th--August 3rd, 2003**

Aspen Grove Loop - 5,200 plus feet—work crew
(depending on rail)

Anytime Projects

Siding Extension - 2 people one day

Steuer siding, extend from 120 feet to 140 feet, install new switch.

Main Yard Tune up - 2 people two weeks

Six Acre Siding and Yard - 2 people 1 week

Six switches, one siding, four stubs.

North Portal Siding, Wye, and Yard - 4 people 1 week

Seven switches, two sidings, one wye, and one stub.

Grade Crossings Upgrade - 2 to 4 people 2 days each

Replace any wooden tie sections within two track sections of all grade crossings (this can be an ongoing project)

And of course there is the always popular, rake pine needles and pine cones fun and games!

RIGHT OF WAY

Constructing the right of way

Winter is approaching and the 'crews' are busy fabricating all kinds of devices to help us in the running and maintaining of Train Mountain. As some of these projects get further along I'll give you some photos to look at and the

(Continued on page 4)

particulars about the 'gadgets' our guys come up with.

CURRENT YEAR

What we've accomplished in 2002

Last issue we showed the long, long list of great things 'we' accomplished at Train Mountain this year. The 'new' Serpentine, Elizabeth River Loop, the new Logging Camp, and on and on. I think we should stand up and take a bow for another great 'building' year at the Mountain! Next year is of course the 'year of the big one' and our focus for the early part of the season will be one of not building, but tuning and cleaning. The world is coming to see this great place 'we' have built and it's 'our' turn to show it off. Remember we are not only the guests but the members. This is 'your' club. This is 'your' world class train layout. This is 'your' chance to show 'your' stuff in it's best light and at the best possible venue. We need to fix, clean, tune, touch up, and do what ever so that when the world sees what 'we' have done, 'we' can be very, very proud. Just as a reminder since most of what has to be done 'before' the 'big one' is clean up and tune up, you don't have to wait for a meet to come do that, you are quite welcome 'anytime' to work on these kinds of projects. This past season we had members like Frank, Al, Art, Art2, Charlie, Jeff, and many others who put in the extra effort that it takes to run a 2,200 acre train park. Please come and help us put on the great show we know we can do! The missing ingredient is YOU!

MAJOR PROJECT STATUS

What is ahead for Train Mountain

Our major project is still the same as reported in last month's Gazette, it's the Worlds largest gathering of 7 1/2 inch gauge engines at the **Worlds Biggest Hobby Miniature Railroad**. We may have as many as 200 plus engines and some 1,500 to 2,000 people at the 'big one' next year. We need lots of planning, lots of volunteers, and some of your time to make it as enjoyable as the 'big one' in 2000. If you are coming and can volunteer some time to help out on any of the many committees, please do so. Check out Triennial Preparations column each month to see what is needed and when. This is going to be another Train Mountain spectacular, I can't wait!

TRACKSHOP

What's built and waiting for installation

Trackshop activities these days are being focused on repairing the Trackshop itself. You can't build as much track as those guys did this past season without leaving some bumps and bruises on the facility. Paul and Mark are rebuilding and fixing up all those things that need fixing and rebuilding. Some of these include some much needed remodeling and some interior wall building. It will make the shop more functional and safer for those of us that volunteer to help in the Trackshop. With the up-grades they are doing, I bet they can beat their **old** record next year, I mean after all they **only** built 64 pieces of

track in **one** day (640 feet)!

WHAT WORKS

Ideas that seem to make a difference

The track adoption program is still looking for additional members to step up and claim a section of Train Mountain. The process is painless and quite simple, give Ross an email or drop him a note at Train Mountain and simply say I would like to adopt the track section from milepost 1.00 to 1.5 or whatever section you would like to adopt. Your obligation is that when you visit Train Mountain, one of your activities would be to go out to 'your' section and check it out. Remove tree limbs, weed, rake, prune, track tune or whatever it takes to 'spruce up' your section. Interested, contact:

Ross Perrin, (General Manager)- tmrrgm@trainmountain.org



PROTOTYPE

The growing collection at Train Mountain

The winter season is approaching and so I don't imagine much work will get done on the various restoration projects in progress. That does not mean though that you can't start your planning for your restoration project. Contact Ross at Train Mountain about your desire to restore some piece of Train Mountain 12" to the foot rolling stock. I'm sure he will be very glad to hear from you!

Ross Perrin, (General Manager)- tmrrgm@trainmountain.org

THE PARK GROUNDS

Its not just trains!

October at Train Mountain is special for lots of different reasons, but the fall colors are just beyond description. My poor digital camera does its best to show you 'some' of the colors, but seeing is believing and what a sight!

FEATURED PRODUCT

From the Company Store

Christmas time is approaching and you had better get your wish lists made out. The Company Store is a great place for your elves to fill that wish list. They have all your railroad goodies in one convenient location, just contact the Office (Carol) - info@trainmountain.org or call 541-783-3030.

(Continued on page 5)

RULES OF THE ROAD

Reviewing the Rules

Safety is our major concern during any operation at Train Mountain, but with the 'big one' coming up it's a good time to review all of 'our' safety practices. This winter while you are completing all of those 'bench' projects why not take a look at your equipment and check it from a safety perspective. For example, are there any sharp edges on the edge of your riding cars, are the seats fastened in good and solid, is your first aid kit in good shape and well supplied? Got the picture, it's not just operating safety it's the complete safety picture. Think about night running, think about all the folks that you are going to be giving rides to at the 'big one'. What can 'you' do to make the 'big one' safer?

OPERATION

More than round and round!

Train Mountain is going high tech these days and I for one am really glad to see these changes. Train Mountain is experimenting with different ways of remotely throwing a switch. Some are manual and one is electric. All look and work terrific. Lets see how they hold up during this winter and then lets watch them spread around the layout.

When approaching South Portal you are now greeted by this really terrific switch stand built by the members of Kitsap Livesteamers. Manually powered and equipped with that handy little flag on the top. Throw the switch one way and the flag says you are headed to South Portal and the Rio Grande Loop, throw it back and you are headed out the Douglas Loop. It is very smooth and easy to operate. The switch stand is located well ahead of the switch and can be reached by NOT getting off of your train. The Kitsap folks say they are easy to build and not too expensive. That's good news because we only need another 20 or so for Train Mountain! Well done Kitsap!



When approaching the passenger station on the Klamath and Western you are greeted by a neat little ground throw switch. It is placed in such a way so that you can pull up to it and lean down and throw the switch 'ahead' of your locomotive. A simple solution to a complex problem. This version is by Art Crisp and has worked great for many years.

FOR THE LADIES

Something for our 'other' halves!

The Chiloquilters sewing group Train Mountain Train Quilt will begin with a tank car for it's first block. We will also be giving some hints on different ways some of the ladies have found to put these blocks together. A special note from your editor, Linda and I are writing the instructions for these blocks and any and all criticism is greatly appreciated. If you have a different way or a better way or have any kind of a question regarding this quilt, please drop us a line: Train Quilt, P.O. Box 927, Chiloquin, OR 97624 or linda@hobby-tronics.com or gazette@trainmountain.org

If you decide to participate in this project remember we are hoping you will make two blocks (one for you and one to send to Train Mountain). We will have lots of different variations of each block so let your imagination run wild.

Chiloquilters Block of the Month Train Quilt Block One, Tank Car

These are the instructions for the first Block of the Month Train Quilt Block. The instructions will be kept simple and

(Continued on page 6)



When approaching the junction for Klamath and Western there is this button on a pole that greets you. Push it once and you are headed towards Grand Junction, press it again and you are headed off to Klamath and Western. The button on the pole is located well ahead of the switch and can be reached by NOT getting off of your train. Its electric motor driven, built by Roll Models, powered by a gel cell battery, and recharged by a solar panel, see I told ya' high tech!



lots of the details will be left up to you. The color selections are completely yours but we will make some suggestions where appropriate. Remember to make two, one for you and one for you to send to Train Mountain for the Train Mountain wall quilt. Here goes.

First off the measurements shown on the diagram are the 'finished' measurements and you should end up with 'finished' 12 inch blocks (12 1/2 inch by 12 1/2 inch). The cut sizes for each piece are shown in the table at the bottom of this page. The sizes shown in the table are with the normal 1/4 inch seam allowance. The most critical measurements are the width of C1 (1/2 inch finished) the height of Strip Three (2 inch finished) and the height of the train track G1 (1/2 inch finished). This should give you exactly 3 inches from the top of C1 to the bottom of G1. This is critical for matching up all the other blocks and having the train track match and the couplers match.

It is our suggestion that you 'build' your blocks by completing one strip at a time and then sew the completed strips together to make your finished block. Special Note: Linda found that it was easier to make the block if she first cut out 'all' the pieces and labeled each piece, then built the block, see cutting instructions below. With that in mind let's build the first strip. Cut out your pieces for 'Strip One' as shown. That's 2 pieces of 4 1/2 x 4 1/2 S1 sky material, 1 piece of 2 1/2 by 4 1/2 S2 sky material, 1 piece of 2 1/2 by 4 1/2 dark tank color T1 material and 2 'tiny' triangles of sky colored SC material. These little triangles look hard but are quite easy. Cut out a 1 inch square of your sky material and place it good side down (right sides together) in the upper left hand corner of the 2 1/2 x 4 1/2 dark tank T1 material (this is the same as doing a snow ball or quick corner piecing). Sew diagonal across the corner as shown in Figure A and fold the 'flap' back. Cut the excess material off as shown in Figure B. Iron the 'flap' to keep it in place as shown in Figure C. We suggest that you sew in all these 'triangle-squares' on each piece 'before' you sew the other pieces together.

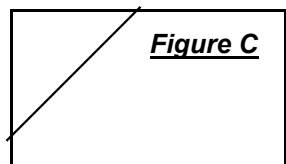
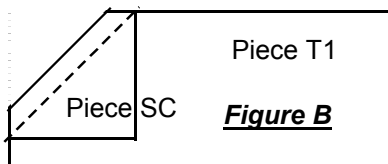
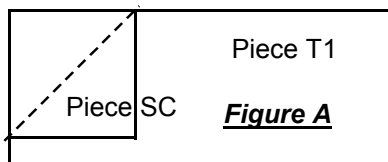

Tank Car Block Copyright 2002
Printed with permission From Chiloquilters

To build 'Strip One' build from left to right, first sew SC onto T1 as shown in Figure A. Repeat for the second SC in the opposite corner of T1. Sew T1 to S2. Sew S1 to the assembled pieces (S2 / T1). Sew the second S1 to the other side of the assembled pieces (S1 / S2 / T1). This completes Strip One.

Strip Two is built from left to right, C1 sewn to S3, Dark Corner C2 sewn to bottom left corner of T2 and SC sky corner to upper left hand corner of T2, assembled C1/S3 sewn to T2, assembled C2/S3/T2 sewn to T3, repeat these steps to complete the right hand end and sew to complete strip two. Special note: press seams towards the center of each piece.

Strip Three is built by building W1 with the SC corners as shown. Then going from left to right sew S4 to the completed W1, add the next W1, sew to S5, complete the right hand end and sew to complete strip three.

Strip Four is built by sewing G1 to E1. *Note: Strips Three and Four will be repeated in most of the remaining blocks for the Train Quilt.*

To complete the block sew the bottom of Strip One to the top of Strip Two, the bottom of Strip Two to the top of Strip Three (special note: these seams won't line up for Strips Two and Three as the rectangles are all different sizes), and finally the bottom of Strip Three to the top of Strip Four. Block One complete!

Cutting Instructions

- S1—2 pieces sky material 4 1/2 x 4 1/2.
- S2—1 piece sky material 2 1/2 x 4 1/2.
- S3—2 pieces sky material 1 1/2 x 4.
- S4—2 pieces sky material 1 x 2 1/2.
- S5—1 piece sky material 3 1/2 x 2 1/2.
- SC—20 pieces sky material 1 x 1 (corners)
- C2—2 pieces dark material 1 x 1 (dark corners)
- T1—1 piece dark tank material 2 1/2 x 4 1/2.
- T2—2 pieces dark tank material 3 1/2 x 4 1/2.
- T3—1 piece dark tank material 4 1/2 x 4 1/2.
- C1—2 pieces dark material 1 1/2 x 1 (couplers)
- G1—1 piece light gray material 1 x 12 1/2 (track)
- E1—1 piece earth colors material 2 x 12 1/2 (earth)
- W1—4 pieces dark material 1 1/2 x 2 1/2 (wheels)

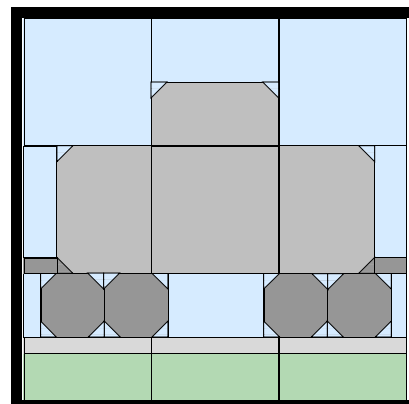

Chiloquilters Train Quilt, Block One, The Tank Car

Strip One

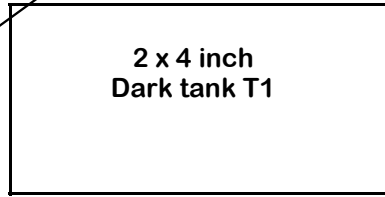
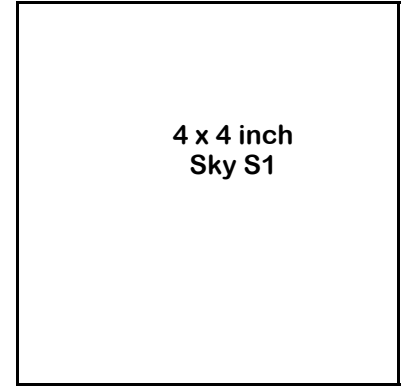
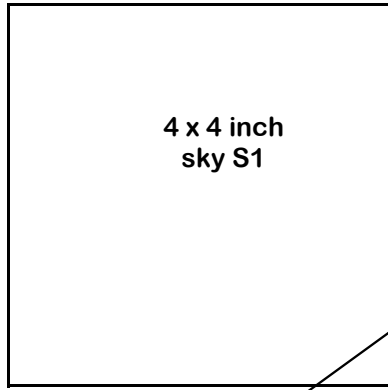

All dimensions shown are 'finished dimensions' remember to allow for 1/4 inch seam allowances when cutting pieces

Strip Two

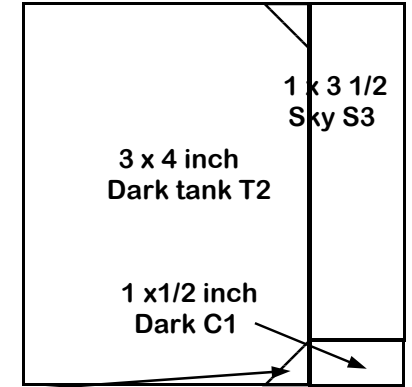
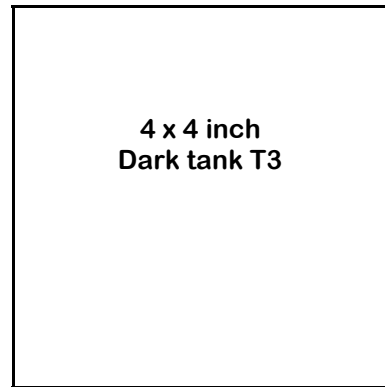
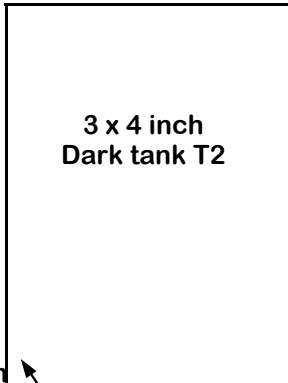
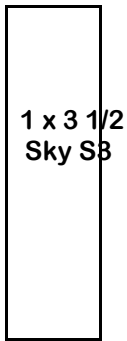

Dark C2

1 x 1/2 inch Dark C1

See special notes about these triangles, they should be sky colors.

Special note: These seams WON'T align vertically, the rectangles are different sizes.

Strip Three

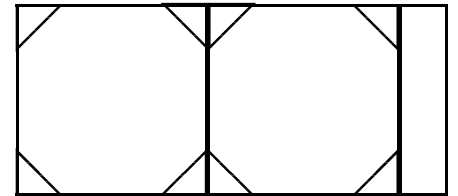
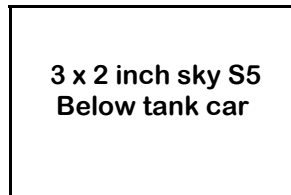

Strip Four

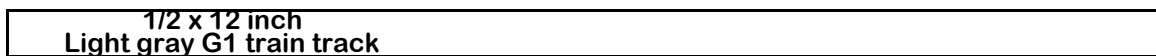

Tank Car Block Copyright 2002
Printed with permission From Chiloquilters



Great livability found in this charming 2 bedroom, 1 bath home! Located off South Chiloquin Road About 1 mile from Train Mountain.



Lot 12 overlooks and goes with the home (or future guest house!), which sits on Lot 14 in a park-like setting. Each neighboring lot is buildable as well or could afford plenty of elbow room and privacy.

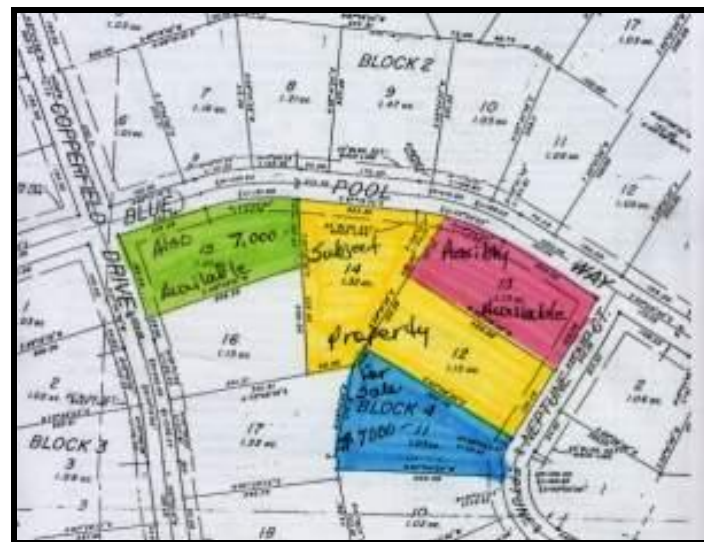

Owner is anxious to sell and listed this at only \$99,500!

Call Sharon at 541-891-2040

CRATER LAKE REALTY



Located at the junction of Hwy 62 and 97

Ranches • Rural Residential • Land

BUS: 541-783-2759
Or 1-800-262-1939

P.O. Box 489
Chiloquin, OR 97624