



# The Mountain GAZETTE

©Copyright 2003, Train Mountain Railroad Museum

An Official Members Only Publication of the Train Mountain Railroad Museum Issue: #26 October 2003

**For the** past several issues I / We have been patting ourselves on our respective backs and saying what a great job 'we've' done. Well we did that's true but I think we all need to remind ourselves that there would be no Train Mountain without Quentin and Sharon. I would like to personally thank them for having 'us' over for playtime at the Mountain. This has been a very tough time for the economy, the country, and for Train Mountain. Through it all the Breen's have been most hospitable, most gracious, and of course most sharing. Thanks for another great bunch of meet's including the fabulous 'Big One' and 'we' all look forward to the next season with a great deal of anticipation.

**Just to** prove my point about hospitable and sharing, please read the following invitation from the Breen's to the members of Train Mountain:

*One of the most lovely times of the year at Train Mountain is fall when the aspens are in their full yellow and orange finery. Though it is now freezing at night, we rarely have our first snow until Thanksgiving and the days are quite pleasant. And, once in six years, Halloween falls on a Friday, allowing it to be the start of a weekend train run.*

*So here is the plan.*

*Trains will be running Friday, Saturday and Sunday. Unlike train meets that are listed in Live Steam, which have registration fees, name badges and are open to non-members, this will be a member's run. This means there are no advance registrations, no registration fees, no meet name tags (but please wear your membership name badges) and the run is open to members and their personal guests only.*

*Friday evening October 31 will be the Train Mountain Halloween party, beginning at 7:00 P.M.. This is a costume party and you can come as anyone or anything you choose. In the past guests have dressed as Matt Dillon, Sherlock Holmes and Lorenzo de Medici, to mention just a few.*

*All day Saturday we will have a fire in the fire pit (complete with spits for roasting and grates for grilling) at the new picnic grounds, located east of the passenger car. There will be picnic tables nearby for those who want to do a barbecue for lunch. The fire will be kept going in the evening for as long as there are brave souls to tend it.*

*None of the Train Mountain campgrounds will be open because the temporary use permits for the summer have expired and the permanent permits have not yet been issued.*

*The track is in fine shape. It should be a good weekend. We look forward to seeing you.*

**Quentin and Sharon**

**So how's** that for an invitation! Here's the info on the Friday Party:

**Friday Oct 31st, 7:00 p.m., Central Station, Train Mountain.** For admission you need to wear the costume of your choice and, if you wish, bring a decorated pumpkin for the annual pumpkin contest. Appetizers, wine & beer. Please bring a dish to share. Sounds like a party to me!

**If you** are having a local celebration be sure to use the wonderful old tried and true 'designated driver' rule and make sure you all make it back to Train Mountain for another season.

**Just when** you think things are a little quiet and there seems to be nothing going on, well you can guess the rest. Since the last issue and this issue we've had our 3rd annual fundraiser for the local community center and once again the bar has been raised. Over \$12,000 dollars raised this year. Our local Chilquilters raised their bar too, to just over \$1,500 for this years quilt raffle. The locals joined in the festivities by giving train rides and mini-tours of Train Mountain. Our thanks to Lee Pirtle, Crystal Panzik and Bob Hayes for their help and trains. In this same time period the earth moving duo of Richard and Ross have been busy re-grading the double track main line right of way from Ellingson Bridge to South Portal. They've also been doing some major grading in the 'pit'! Helping on all this was of course Sonya and Sarah who had the 'dirty' task of pulling up all that old plastic from under that old ballast, yeech! It's looking great and I can't wait for the next building season to get under way to put it all back in the latest Train Mountain manor.

**With this** issue we are doing another For The Ladies quilt block. This time it's the tender (coal car) for last years steam engine. As reported in last months issue, the ceremonial 'first' train quilt was presented to Quentin and Train

*(Continued on page 2)*

Mountain by Louise Balf. This is one of many and was chosen by the ladies to represent the accumulated work of all so far. Train Mountain is still accepting finished blocks or finished quilt runners from you ladies so please don't be bashful, send them in and they will adorn the walls of Central Station for years to come.

**Table of Contents**  
**From The Manager** 2  
**Next Work Week** 2  
**What Works** 3  
**Prototype** 3  
**Operations** 4  
**Triennial Review** 4  
**For the Ladies** 5



**FROM THE MANAGER**  
**The latest information**

Fall is here and what a great time for a train ride. It is a little breezy and cool but the changing colors out in Douglas Meadow and the increase in wildlife is well worth it. And talk about pine needles! The fall shedding of old needles seems to be very heavy this year, guess what that means. Yes, they are piling up on the tracks, all part of the fall season.

The Crisp Yard project is shaping up, most of the gravel has been removed and a lot of new track (aluminum with plastic ties) has been installed. The removal of those annoying humps coming off the steaming bays will sure be nice, but the redesign also gives way to longer storage tracks, which in many cases means longer trains can use the yard.

Out in the Carpenter Shop, the Produce Warehouse structure is pretty much done and they are still building crates, shipping containers and boxes. This will be another of Ron and Caroline's premier buildings, right down to the fruit and vegetables in the crates.

Progress is being made out by South Portal; the lift of dirt is almost in place and will be able to settle over the winter, also some interesting cuts being made to allow access to the pit. This area is on its way to being another great attraction for all to enjoy.

One of our winter projects this year and for many to come is fencing. You may not realize that we have many miles of fence to maintain and install. The north end of Train Mountain had over 3300 meters of fence removed for a highway realignment project which has to be reinstalled and fence line roads built. Our western border is in need of clearing and fencing, along with a long stretch of the southern border. Many areas now have posts in and just need wire hung, but all of it needs maintenance. For many years we had a serious problem with poaching and we have almost brought that to a halt by fencing key areas. This process of securing TM will be a continuing project, with the result intended to protect the wildlife and property that adds to the Train Mountain Experience.

As a business, we have to make choices that are hard to swallow sometimes. Due to economic times affecting us and also changes in work load in the Fall and Winter Jerry Day from the Backshop will be going on to bigger things. Jerry came on board after the IBLs 2000 meet and has been a great asset, he has completed many projects and through his persistence to see TM progress we have more trucks under cars than ever before. We will miss having him at work everyday. I hope he will stay involved and we will still get to have him around as much as possible.

Talk to you soon

**Ross**

Ross Perrin, (General Manager)- [tmrrgm@trainmountain.org](mailto:tmrrgm@trainmountain.org)

**NEXT WORK WEEK**  
**What do we do next!**

**Tune up**, fix up, spruce up, whatever you want to call it, that's what we need to do next. Please give us a hand at accomplishing these tasks. Also remember to plan enough time to have **fun** while you are here!

Meet	Work Week	Train Meet
First 2004	Sat May 29-Thurs June 3	Fri June 4- Sun June 6
Second 2004	Sat June 26-Thurs July 1	Fri July 2- Sun July 4
Third 2004	Sat, July 31-Thurs Aug 5	Fri Aug 6- Sun Aug 8
Fourth 2004	Sat, Sept 4-Thurs Sep 9	Fri Sept 10- Sun Sept 12
First 2005	Sat May 28-Thurs June 2	Fri June 3- Sun June 5
Second 2005	Sat July 2-Thurs Jul 7	Fri July 8- Sun July 10
Third 2005	Sat, July 30-Thurs Aug 4	Fri Aug 5- Sun Aug 7
Fourth 2005	Sat, Sept 3-Thurs Sep 8	Fri Sept 9- Sun Sept 11
First 2006	Sat May 27-Thurs June 1	Fri June 2- Sun June 4
<b>Triennial</b>	<b>Wed June 21-Sun June 25</b>	<b>Mon June 26- Sun July 2</b>
Third 2006	Sat, July 29-Thurs Aug 3	Fri Aug 4- Sun Aug 6
Fourth 2006	Sat Sept 2-Thurs Sept 7	Fri Sept 8- Sun Sept 10

*Please note the changes for the 2006 Triennial, the work week has been shortened to 5 days and the Triennial has been shortened to 7 days. This is to help with volunteer burnout but still give you lots of time to have some fun here at Train Mountain.*

**Possible First 2004 Work Week Projects**  
**May 29th--June 6th, 2004**

**Relay Outside Mainline**—Ellingson Bridge to South Portal—1,500 plus feet double track—work crew

**Aspen Grove Loop** - 5,200 plus feet—work crew (depending on rail)

*(Continued on page 3)*

## Anytime Projects

### **Siding Extension - 2 people one day**

Steuer siding, extend from 120 feet to 140 feet, install new switch.

### **Main Yard Tune up - 2 people two weeks**

### **Six Acre Siding and Yard - 2 people 1 week**

Six switches, one siding, four stubs.

### **North Portal Siding, Wye, and Yard - 4 people 1 week**

Seven switches, two sidings, one wye, and one stub.

### **Grade Crossings Upgrade - 2 to 4 people 2 days each**

Replace any wooden tie sections within two track sections of all grade crossings (this can be an ongoing project)

*And of course there is the always popular, rake pine needles and pine cones fun and games!*

---

## **WHAT WORKS**

### **Ideas that seem to make a difference**

**Are you** one of those kinda' folks like me that when the Harbor Freight or Northern tool sale paper comes in the mail, you read it from cover to cover and scope out all the neat goodies. Well if ya' are read on. How about this winter we all work on some 'gadgets' for use in our hobby. Over the past few seasons I've seen some mighty clever gadgets for doing things like re-railing trains, or how about those great track mirrors for doing track maintenance. Just think with all of our members worldwide what a great brain trust we have access to. And think of what it would mean to the hobby to publish some of those great ideas here in The Mountain Gazette. To sort of get the ball rolling I'll start with a project I saw in progress in the Backshop the other day, and that's some re-railers for Train Mountain use. They are made in pairs (a left and a right), are very portable, and are available through the company store if you are not inclined to do some cutting, drilling, welding, and filing.

---

## **PROTOTYPE**

### **The growing collection at Train Mountain**

**I'm always** on the lookout for projects that can be done by members while they are here at Train Mountain, but that don't necessarily involve lots of strenuous effort to complete. So much of our summertime work is building track or weeding or whatever, but it is strenuous. So how's this for a great project. Next trip here, bring your camera and pick out one of the prize pieces of rolling stock that Quentin has brought to Train Mountain and adopt it but adopt it as a 'photo project'. What do I mean 'photo project'? Well here's the plan, over some period of time most of the rolling stock will be renovated, cleaned up, and spruced up. We need to have a very complete photo record of where the lettering was and what it said. What decals were where and what did they say. We need detail shots of the entire car from top to bottom, end to end, and inside and out. This info will then be added to the website and will be yet another valuable resource for

the hobby and for railroaders everywhere. Go to the Train Mountain website and look at the extensive list of prototype rolling stock that is already located at Train Mountain and you can see we have lots to shoot and document. Here's just the SP stuff: Southern Pacific Bay Window Caboose #4758, #4755, #4753, #1967, #1952, #1950, #1938, #1861.

The SP caboose 4000 series were originally part of the series SP 1400 to SP 1599, which totalled 200 cabooses, and were built by the Pacific Car and Foundry Company of Renton, Washington, in 1961, at a cost of \$19,000. Originally equipped with 7 rotating chairs and 2 two-person reversible chairs in the bay windows, subsequent modernization reduced seating capacity to 5 rotating chairs and 2 rotating chairs in the bay windows, and replaced the flush hopper with a Microphor toilet with on-board sewage treatment system. Other changes included replacing two side windows with adjustable vents, the addition of FRA safety glazing and installation of a 12V DC refrigerator/water cooler. The caboose series dimensions and weights follow:

Length over pulling faces of couplers 42'-63/8"

Length over platform end sills 38'-13/8"

Length over body end sills 32'-65/8"

Width over side plates 8'-75/8"

Width over bay side sheets 10'-61/4"

Height, top of rail to top of roof 12'-311/16"

Weight of body 49,960 lbs.

Weight of trucks 15,560 lbs.

Total Weight 65,520 lbs.



The trucks are Barber-Bettendorf swing bolster type with leaf springs and have 33" wheels with roller bearings. The B end truck is equipped with a 12V DC alternator which charges the 12V battery which supplies power for the lights, radio and refrigerator. The heating stove is oil-fired, and the oil tank is beneath the single bunk.

*(Continued on page 4)*

## OPERATION

### More than just round and round

If you haven't been following the great progress being made on the Train Mountain website and in particular the Track Survey section, I would highly recommend you take a look at: <http://www.trainmountain.org/TrackSurvey.aspx> Bill Sheppard and Glenn Peterson have been doing a great job of building a dynamic track map. You can zoom it, pan it, and really get a sense of the size of Train Mountain. They have plans to incorporate more features and in the near future will be asking for out input into what new features we might want. Please take a look you will be amazed!

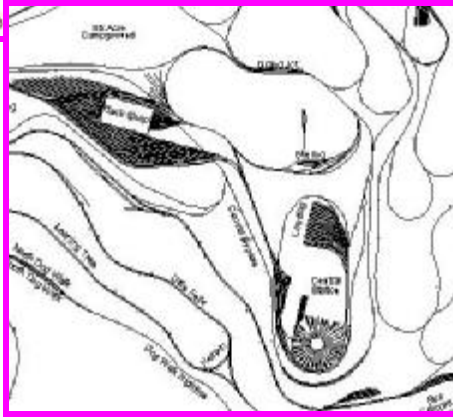
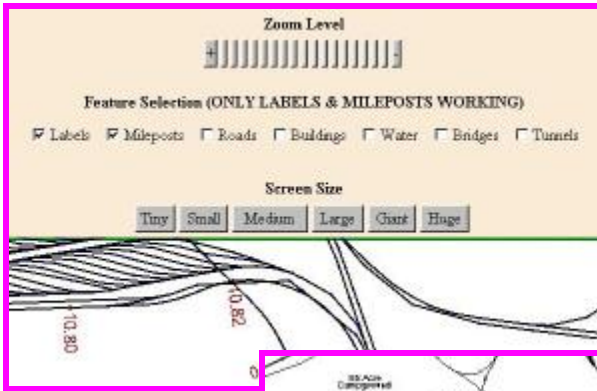

Just a couple of screen shots to wet your appetite for what's coming from these guys. The potential is enormous, I can't wait to see what's next! Great job guys!

## TRIENNIAL REVIEW

### Just a few of our great vendors!

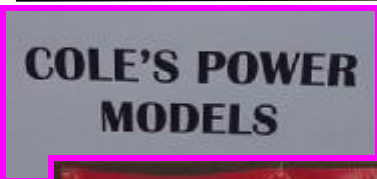

# Chiloquilters Block of the Month

## Train Quilt, The Steam Engine Tender

These are the instructions for the Block of the Month Train Quilt Block. The instructions will be kept simple and lots of the details will be left up to you. The color selections are completely yours but we will make some suggestions where appropriate. Remember to make two, one for you and one for you to send to Train Mountain for the Train Mountain wall quilt. Here goes.

If you made last month's block you will see this month's block is even easier. It still has the same Strip Three and Four. But the rest is easier.

The Steam Engine Tender (sometimes called the 'coal' car) is a vital part of a steam engine. It carries the fuel (wood-old time, coal, oil) and the water for the steam engine. It goes directly behind the steam locomotive.

Strip One is easy to build this month, just cut it out! S1.

Strip Two is built by sewing S3 to T1, sew the Sky corner piece S4 to T1, add S5 to the strip. Sew the top of T2 to the bottom of T1. Sew the two C1's to the two S2's. Sew both the S2 strips to T1/T2.

Strip Three is built by making the W1 wheels the same as last month (see figures below), then sewing S3 to the completed W1, add the next W1, sew to S4, complete the right hand end and sew to complete strip three.

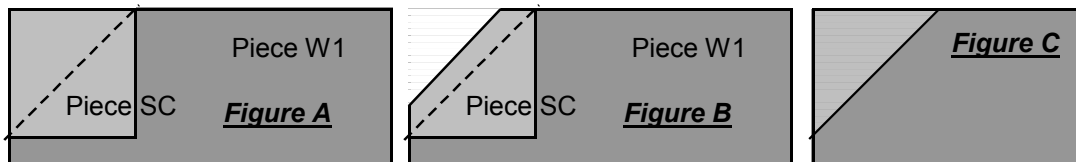

Strip Four is built by sewing G1 to E1. *Note: Strips Three and Four will be repeated in most of the remaining blocks for the Train Quilt.*

To complete the block sew the bottom of Strip One to the top of Strip Two, the bottom of Strip Two to the top of Strip Three (special note: these seams won't line up for Strips Two and Three as the rectangles are all different sizes), and finally the bottom of Strip Three to the top of Strip Four. Block Three complete!

Start thinking about the finished size of your quilt as that will determine how many of the blocks you will need. As an example a 6 x 7 block quilt will require 42 of these blocks to complete the quilt. We will have dimensions for the more popular size quilts in future issues.

### Cutting Instructions

S1—1 piece sky material 4 1/2 x 12 1/2  
 S2—2 pieces sky material 1 1/2 x 4  
 S3—1 piece sky material 1 1/2 x 1 1/2.  
 S4—1 pieces sky material 1 1/2 x 1 1/2 (corner)  
 S5—1 piece sky material 1 1/2 x 4 1/2  
 S6—2 pieces sky material 1 x 2 1/2  
 S7—1 piece sky material 3 1/2 x 2 1/2

SC—16 pieces sky material 1 x 1 (corners)  
 T1—1 piece steamer material 1 1/2 x 5 1/2 or  
 T2—1 piece steamer material 3 1/2 x 10 1/2.  
 C1—2 pieces dark material 1 1/2 x 1 (couplers)  
 G1—1 piece light gray material 1 x 12 1/2 (track)  
 E1—1 piece earth colors material 2 x 12 1/2 (earth)  
 W1—4 pieces dark material 2 1/2 x 2 1/2 (wheels)

A special note from your editor, Linda and I are writing the instructions for these blocks and any and all criticism is greatly appreciated. If you have a different way or a better way or have any kind of a question regarding this quilt, please drop us a line: Train Quilt, P.O. Box 927, Chiloquin, OR 97624 or [linda@hobby-tronics.com](mailto:linda@hobby-tronics.com)

# Chiloquilters Train Quilt, The Steam Engine Tender

All dimensions shown are 'finished dimensions', remember to allow for 1/4 inch seam allowances when cutting pieces

Strip One



Strip Two

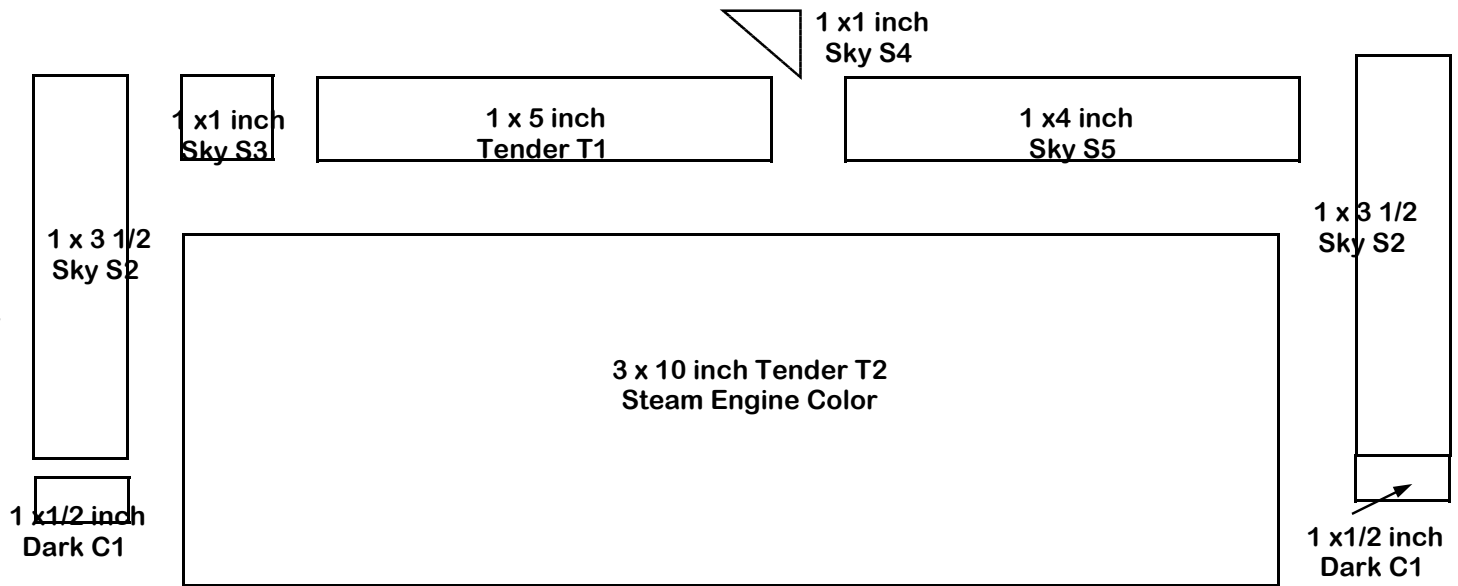

Strip Three

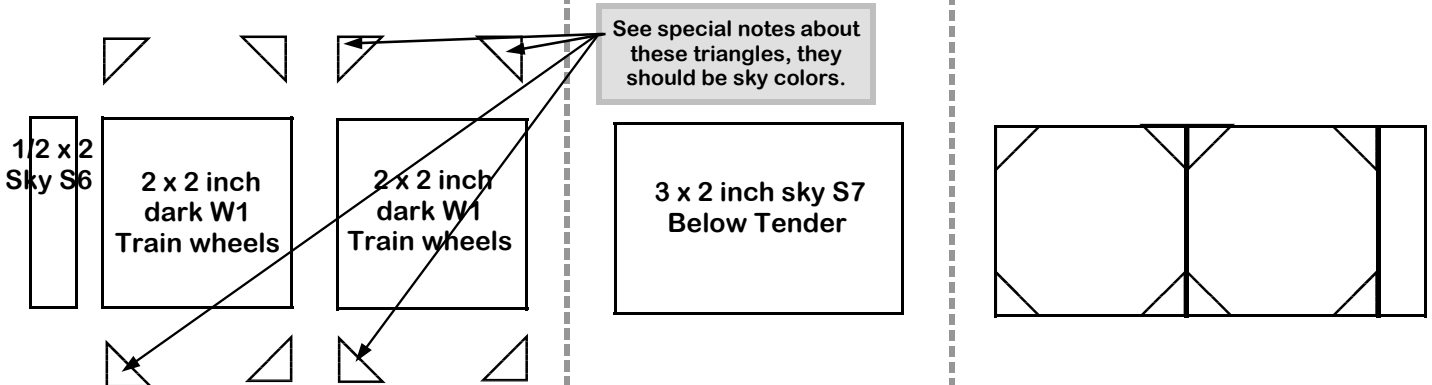

Steam Tender Block Copyright 2003  
Printed with permission From Chiloquilters

Strip Four

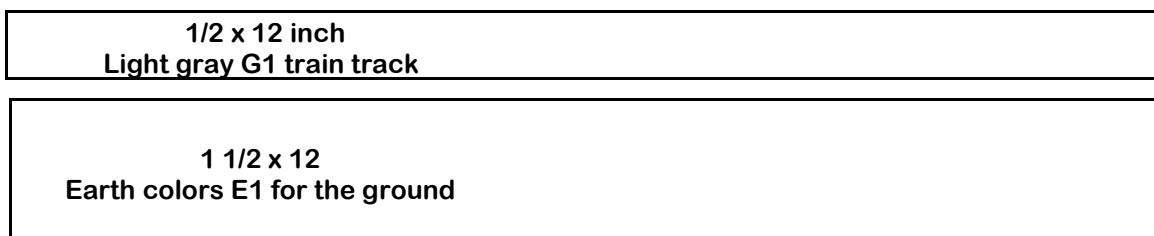



Awesome custom home with beautiful oak cabinets, doors and window trim, on South Chiloquin Road near Train Mountain.



Extra wide double garage is attached to this 2 bedroom, 2 bath, 1485 sq.ft. dream. Great living on 2.5 acres in the pines. Great landscaping and garden area has been a delight this summer! Imagine waking up in this lovely master bedroom!



**Was \$192,000, reduced to \$182,000.**  
**Hurry and call Sharon to learn more!**  
MLS #51437

**Contact Sharon Breen**  
**Cell: 541-891-2040**

**CRATER LAKE REALTY**



Located at the junction of Hwy 62 and 97

**Ranches • Rural Residential • Land**

BUS: 541-783-2759  
Or 1-800-262-1939

P.O. Box 489  
Chiloquin, OR 97624