



The Mountain GAZETTE

© Copyright 2013, Train Mountain Railroad

An Official Members Only Publication of the Train Mountain Railroad Issue: Vol. #2 Issue #7 May 2013

From the Editor - Russ Wood

Once upon a time in a land far, far away, *well rural Oregon*, there was a magic kingdom called Camelot, oops wrong story, called Train Mountain. In this kingdom here was a king called Quentin of Breen and a queen called Sharon of Breen. All was good for many years and in his kingdom he taught us all how to share and how to have fun doing very laborious tasks. Many came to share in this dream kingdom, workers of steel, builders of models, lovers of the land, and many other skills. Then all was not good as the king was ailing and after a terrible time he passed on to a different kingdom. This seemed to be the end of the wonderful dream as things continued to go bad for the kingdom and the lady to whom the torch had been passed, Sharon of Breen. While many had tried to come to the aid of the kingdom, there was but one who was able, a very special one from another kingdom, a kingdom called Friends of Train Mountain. The valiant efforts of the neighboring kingdom fought one foe after another, so the kingdom kept on. All seemed well in the kingdom once again, but then a great dragon encroached upon the kingdom, some called this fearful dragon the IRS, the dragon demanded a great toll to be paid by the kingdom to keep the dream kingdom alive. This is where the dream could have turned into a nightmare and for a while all thought the end was near. All except for the king and queen of the neighboring kingdom. The king Carl of Vanderspeck and queen Marg of Hope, they rallied their knights of the round table to pick the mightiest of their ranks to do battle against the fearful dragon. The choice was clear it had to be Sir John of Black. Sir John of Black was a good choice as he had slain other dragons in the past, the dragon of property tax, the dragon of CUP, and more. So Sir John of Black set forth to slay the dragon armed not with swords or spears, but skill, cunning, and a stack of paper over 5 inches thick! After much time the dragon was slain, and once again all is good in the magic kingdom of Train Mountain.

OK I am making light of a most serious set of events. But what I am trying to do in my own way is to get to the main point of the story. We owe a great deal to many folks for keeping Train Mountain alive and well. Of course Quentin whose dream we are trying to keep alive. To Sharon for struggling for a couple of years and suffering though a lot of heartache and through very troubling times to keep Train Mountain's head above water. To Carl and Marg for toughing out all of the ups and downs of Train Mountain and to keep their love for Train Mountain at the forefront of their fund raising efforts. To John Black for spending thousands of hours, thousands of miles back and forth cross country, and countless time in meeting after meeting to slay the dragons. How do you say thank you to such people. It's just two little words. Thank You! Maybe if we all go to the window and shout it out, we can add to it, but however we say it, the real feelings are all there, thank you, thank you, thank you.

To read all about the slaying of the dragon please see:

http://www.tmrr.org/Resources/tmrrdocs/Goodbye_IRS.pdf

The Narrow Gauge meet was awesome! Over 80 members in attendance and wow, the gorgeous equipment was wonderful. We were all having a great time and at the member dinner on Wednesday night, John wheeled in a cart with Champaign glasses and many bottles of Champaign. He gave a very brief speech and then a toast, the IRS is paid! The liens against Train Mountain are history! So needless to say the rest of the meet was all smiles, even more smiles than what was already there. A great meet, and of course a great celebration of a great milestone. Please see the Photo Gallery for pix of the meet.

From the President - Jim Armstrong

It Has Happened!! The IRS liens against Train Mountain have all been discharged.

On Wednesday evening, May 8th there was cause for a big sigh of relief and joyous sounds of celebration coming from the Hall of Flags at Train Mountain.

From the TMRR Board of Directors and the TM Membership, a most sincere and heartfelt Thank You goes out to Carl Vanderspeck, Marg Hope, and John Black for their tireless efforts, continual support, and generous donations of money and time toward getting the liens discharged. You can learn of all the details from the "Good Bye IRS" article elsewhere in this issue of the Gazette.

And Thank You to the many, many other members and non-members for their support and time spent in reaching this goal. We must all now join together and proceed forward with maintaining and growing Train Mountain to its fullest potential.

With the Narrow Gauge Meet almost over and the June Meet just a couple of weeks away, the Mountain is again alive with train enthusiasts from across North America. It feels good to get the 2013 Meet Season off to a strong start. Have you made your plans to attend one or more meets this year?

There are plenty of things to do before each meet. Volunteer activities during the upcoming work weeks include forestry care, grounds maintenance, track maintenance, model building maintenance, weed abatement, and much more. All these activities can enhance the pleasure of your visit and give you a feeling of accomplishment that you have contributed to making Train Mountain the grand facility it is.

Your Board of Directors and other members are busy working on: future project plans and their funding, getting a small rental fleet of rail bikes ready for your enjoyment, and tending to the many details involved in preparing for your arrival this year.

Hope to see each one of you at a meet this year. Drive carefully and have a wonderful summer.

Containerville Dirt Work - Jerry Crane

Here are the actions required to complete the dirt work for the next row of storage containers:

1. Determine how far apart the two rows of containers will be and where the ecology blocks need to be installed and there height.
2. Dig a trench for the ecology blocks at the required depth, being careful not to go too deep. The block should be placed on undisturbed soil.
3. Install the ecology blocks and back fill around them.
4. Remove the unwanted soil so that the top of the ecology blocks are about 3 inches above grade. Slope the soil so that the earth is about 6" down between the two rows of ecology blocks between the south and the (to be installed) north containers
5. Dig about a two foot deep trench and install a 3/4" conduit just north of the existing containers. This conduit needs to run from just under the electrical panels west of the containers to a point between the east and west containers. Stub up at both ends.

<u>2013 Train Mountain Train Meet Schedule</u>					
	June Train Meet	Operations Meet	August Train Meet	September Train Meet	Fall Colors Train Meet
Work Week	5/25 to 5/30	6/22 to 6/27	7/27 to 8/1	8/31 to 9/5	none
Meet	5/31 to 6/2	6/28 to 6/30	8/2 to 8/4	9/6 to 9/8	10/11 to 10/13

6. Dig the French drain trench. This trench needs to be run from east to west centered between the south and the (to be installed) north containers. Use a bucket about 1.5' wide. The trench needs to slope down from the east end to the west end. Start at about 1.5' deep at the east end and end at about 3' deep at the west end. Dig the trench over to the metal manhole just west of the containers.
7. Install about 3" of gravel on the bottom of this trench.
8. Install a perforated 4" of 6" plastic pipe in the trench. There is some down in the bone yard.
9. Run the pipe over to the manhole. Cut a hole in the side of manhole and insert pipe.
10. Cover the pipe with landscape cloth.
11. Fill the trench with gravel to grade. Keep weight on the pipe when backfilling or the pipe will tend to move up.
12. Lay plastic from each side of the trench out to the ecology blocks.
13. Fill area between ecology blocks with gravel. Needs to be only about 2" deep.

Tent Catapillars - BOD (a repeat from last month)

Train Mountain has a major Tent Caterpillar problem that we need to aggressively get under control. Tent Caterpillars are a serious problem because they eat so many of the leaves on a bush that the bush dies and becomes serious fuel for any fire. If we do not kill the Tent Caterpillars, we are asking to lose Train Mountain to a fire.

Tent Caterpillars construct and enlarge white silken tents while consuming adjacent foliage. We need to cut off the branches with these tents, collect them in Plastic Bags, Take them to the Garbage Cans by the office, and then they will be burnt to kill them. Please be sure to put the covers on the garbage cans. The office is keeping a map showing the areas where Tent Caterpillars have already been harvested.



What I do at Train Mountain - Dennis Ward

Most days I arrive at the office at about 8:00 AM. I make coffee or pour myself a cup of coffee made by the folks staying at Central Station. I try to go over the email which has come into info@tmrr.org in order to process any documents which pertain to internet memberships or meet registrations and to process orders for the store such as Triennial Videos.

If there are membership applications then I will prepare membership packets so that they will be ready to go to the post office with Charlie Bill Schubert. Charlie goes to the post office almost every morning to check the Train Mountain Railroad (TMRR) mail box and to post any outgoing mail which is ready to go. This may include store merchandise which is sent via the United States Postal Service.

Upon Charlie's return from the post office we go over the mail and attempt to distribute it to the correct person. A good share of the mail contains meet and membership registration which need to be processed. Charlie and I prepare lists for Tom Watson (for name tags, meet badges, etc.) and for Russ Wood who uses his amazing ShopBot™ CNC router to create the permanent plastic name badges.

If there are no interruptions the above activities as usually completed by 10:00 AM. Rarely does my morning go without interruption. Member's and/or passersby stop by with question about or business with TMRR. Or just to chat. Tom Watson, Russ Wood or I usually answer the phone but we have had some help from Charlie Bill, Delores Bartholomew, Barb and Dana Ward and others who can stand by the office while Tom ,Russ and I are out of the office.

Other things that I do are prepare membership rosters, meet statistics, financial reports. I prepare bank deposits and usually get them to the bank weekly. Friends and family help frequently by taking the deposits to the bank. I also help train other TMRR volunteers to do some of the office tasks.

If time and weather permit I may even get outside to pick up forest debris (pine needles) or work on the track. This has not happened as much as I would like. If I learn to work more efficiently I may get to spend more time outside working and playing on the railroad. As it is I spend in excess of 40 hours per week volunteering in the office at Train Mountain. I would rather be outside working and playing. WE NEED MORE VOLUNTEERS.

Letter to the Editor - Russ Wood

In keeping with Dennis's piece above I thought I would add this email posting from the FriendsTM email forum. If you can volunteer some time at Train Mountain, the place we love needs your help. Boyd Butler explains the problem very well. He writes :

There are only a few who even work on the track, cleaning needles or fixing it. We have lost the help of three of those people that are now in the office. This leaves only about four more to do work on trains for K&W and to do the track work. We are in desperate need of outside help. The track is not in good shape and that should be the first thing that is done each year. This year the track has had very little work done on it and without it we are going to have trouble hosting any meets. I have been over all of the track south of the highway spraying and thru M&M Corner and Aspen grove. There is some of the south area that made me very uneasy to run over, switches that do not throw completely causing several derailments. The north area is not much better than south area. What I am getting at is we can do many things off of the long list of projects, but the most needed work right now is the track work, needles picked up, and branches trimmed, then we can move on to other things on the list. Like I said the pool of people who are on site week after week is very small and those out on the track working on it is even smaller. Boyd

If you can give some time... especially early in the season, it would really help.

THE IRS LIENS ON TRAIN MOUNTAIN ARE ALL COMPLETELY DISCHARGED - Friends of TM

On May 8th, 2013 Friends of Train Mountain, as Custodian of Train Mountain discharged all the IRS liens on Train Mountain and transferred ownership of the real and personal property to Railroad Institute.

On August 27, 2009 the IRS filed \$17.3 million in liens against Train Mountain to collect IRS debts of TM founder Quentin Breen and his businesses :

\$ 3,500,097 on Train Mountain Foundation properties
\$ 3,500,097 on Train Mountain Railroad Museum properties
\$10,326,552 on Train Mountain Inc properties

\$17,326,746 Total

Three years later.... August 1, 2012, the Klamath County Courts appointed Friends of Train Mountain as Custodian of Train Mountain with authority to negotiate with the IRS. On August 2nd, Friends gave the IRS 5" of paper... prepared in consultation with appraisers... documenting what we thought was the value of TM. After a 9 month negotiation, the IRS accepted a \$664,823 offer as payment in full to discharge those liens and transfer ownership of Train Mountain to Railroad Institute (RRI). In addition, there were some title insurance, recording, and closing costs that brought the total to \$670,956.

The funds were raised as follows :

\$ 5,000 Paid to RRI by Carl Vanderspek & Marg Hope.

\$ 31,000 Paid to RRI by Friends of Train Mountain for modifications to existing Track Rights Agreement, Scenic Easement, and Lease.

\$170,956 Cash on hand in Train Mountain Custodial accounts

\$464,000 Proceeds from a Mortgage that can turn into a donation.

\$670,956 Total

For \$670,956 RRI gets title to everything at Train Mountain.... both real and personal property.... including the Steiger Butte cell tower leases which produce over \$60,000 a year in income.

The Court's Stipulated Orders gave Friends of Train Mountain as Custodian the authority to transfer the ownership of Train Mountain to Railroad Institute. Railroad institute is a 501c3 Public Benefit Non-Profit.... so essentially the public now owns Train Mountain. If RRI ever goes out of business, its assets are to be distributed to other non-profits.

What saved Train Mountain was that the Friends of Train Mountain Lease, Track Rights Agreement, and Scenic Easement gave Friends so many rights that the property had little value on the open market.

More Detail at http://www.tmrr.org/Resources/tmrrdocs/Goodbye_IRS.pdf

Welcome Train Mountain Institute

Railroad Institute has filed paperwork with the State to change its name to Train Mountain Institute. A new website will be available in June at www.TMInst.org.

The name change is part of our effort to have One Train Mountain. Our situation and the non-profit laws force us to have more than one legal entity, but we want to act like a single project.

Witcombe Re-Grade

Right after the Narrow Gauge Meet we tore up Witcombe to re-grade the legs of the Wye so the track from Witcombe to Aspen could tie in. As I write this the grade is mostly done and the culvert is installed. We are waiting for the ground to dry out enough so we can finish it to plastic ready with the grader.

The Next Big Project is 2 projects : Hairpin & Containerville

Hairpin --- Right after the June meet we will tear out the aluminum rail on wood ties from the end of steel track north of Hairpin to Bottleneck Crossing and to where the service road touches the grade at about milepost 0.845 near Deadwood. This is some of the oldest track at Train Mountain. There is a tall, narrow fill that is deteriorating. We will haul in 70-100 loads of fill dirt to widen the existing fill and re-slope its banks. This big fill will need to sit over a winter to settle so we will not lay track on it until next year.

The aluminum on wood rail that we take up will be available for sale for \$30 per panel... \$250 per switch. The track can be re-used if the ties are turned over. There is also a little track available for \$50 per panel where the ties were turned over and refastened in 2007. The rail has to stay at Train Mountain. Containerville has first priority in using this rail.

Containerville ---- About 30% of the fill dirt for Hairpin will come from preparing for the second row of containers at Containerville. The area under these containers and surrounding them has to be lowered about a foot. Then ditches need to be dug to install a French Drain between the container rows and to install the Ecology Blocks that will serve as foundations for the second row of containers. We plan to install the Ecology Blocks as part of this project.

The rest of the fill dirt for the Hairpin project will come from the burn pit area.

Cash Position

We are low on cash. We spent everything we had to discharge the IRS liens. Here is the Cash Position on May 22, 2013.

\$33,864.00	Cash in the Bank
\$12,000.00	Estimated Accounts Receivable
\$(3,000.00)	Estimated cost to close Dobbs Sale
\$(1,940.00)	Checks outstanding
\$(4,500.00)	Reserve for Gardening Expense
\$(10,200.00)	Reserve for Property Taxes
\$(25,202.00)	Triennial Funds held by Custodian
\$1,022.00	Available Cash

Six Month Financials

We have been operating Train Mountain for 6 months.... November 2012 through April 2013. Here is how the entities are doing.

Railroad Institute (now Train Mountain Institute) is still dormant. It will be coming alive by July.

Friends of Train Mountain is continuing to employ Dustin, Richard, Raven, and Debra thanks to donations by its members.

Train Mountain Railroad has sold \$20,820 in memberships and \$3,520 in meet fees. These numbers are less than we had hoped. The IRS lien and the Timberlake gates have made some people hold back. We all need to encourage our friends to join Train Mountain.

Friends of Train Mountain as Custodian has administered the "Basic Operating Budget" which pays the costs of keeping the doors open at Train Mountain. Soon this responsibility will transfer to Train Mountain Institute. On the following pages you can see the last 6 months of numbers.

Notes :

All the accounting is now being tracked in Quickbooks Online by Dennis Ward and/or John Black. The books reconcile to the bank statements. So we have good books. Every time we extract data to build a spreadsheet like the ones on the next 2 pages, there is always the opportunity for an error to slip in. We know the numbers well enough to know that these spreadsheets are substantially accurate, but we have not audited the numbers.

In addition to the revenue shown on the next 2 pages, there is about \$4,000 in revenue from the store. I just ran out of time and did not get that story detailed.



Custodian Revenues after Nov 1, 2012

Revenues to TM Operations Fund	Nov	Dec	Jan	Feb	Mar	Apr	Total	SubTotals	Budget	
TMRR Share Memberships / Meets	\$ 5,868.20	\$ 2,664.00	\$ 3,907.20	\$ 1,783.40	\$ 2,275.50	\$ 2,293.26	\$ 18,791.56	\$ 18,791.56	\$ 35,057.50	54%
Rents										
StJohn Residence Rental							\$ -		\$ 1,600.00	0%
Q's Apartment Rental							\$ -		\$ 4,800.00	0%
Hall Rental to outside parties				\$ 200.00			\$ 200.00		\$ 1,000.00	20%
Member Guest Accommodations					\$ 60.00	\$ 390.00	\$ 450.00		\$ 3,200.00	14%
Backshop Storage							\$ -		\$ 900.00	0%
Container Rentals					\$ 187.50	\$ 1,426.25	\$ 1,613.75		\$ 7,500.00	22%
K&W Annual Lease Fee							\$ -		\$ 800.00	0%
Campground Fees							\$ -		\$ 500.00	
Container Lease Sales	\$ 4,900.00						\$ 4,900.00		\$ 10,000.00	49%
Riding Car Rental							\$ -		\$ 500.00	0%
Railbike Rentals							\$ -		\$ 1,000.00	0%
Store	\$ 60.00	\$ 638.40					\$ 698.40		\$ 5,000.00	14%
Beanery							\$ -		\$ -	
Fuel Yard							\$ -		\$ 500.00	0%
							Subtotal Rents	\$ 7,862.15	\$ 37,300.00	21%
Contributions				\$ 1,200.00	\$ 500.00		\$ 1,700.00	\$ 1,700.00		
Other Income										
Unexplained Check	\$ 149.83									
Cash	\$ 74.55									
Cash	\$ 25.11									
Insurance Refund		\$ 7.00								
							Subtotal Other Income	\$ 256.49	\$ 1,000.00	26%
Cell Towers										
AT&T	\$ 850.00	\$ 850.00	\$ 850.00	\$ 1,046.76	\$ 850.00	\$ 850.00	\$ 5,296.76		\$ 10,200.00	52%
Verizon	\$ 1,396.49	\$ 1,396.49	\$ 1,396.49	\$ 1,396.49	\$ 1,396.49	\$ 1,396.49	\$ 8,378.94		\$ 16,800.00	50%
US Cellular	\$ 959.88	\$ 959.88	\$ 959.88	\$ 959.88	\$ 959.88	\$ 959.88	\$ 5,759.28		\$ 11,500.00	50%
SBA/Towerco	\$ 1,313.51	\$ 1,313.51	\$ 1,313.51	\$ 1,313.51	\$ 1,313.51	\$ 1,313.51	\$ 7,881.06		\$ 15,800.00	50%
SBA	\$ 1,194.11	\$ 1,194.11	\$ 1,194.11	\$ 1,194.11	\$ 1,194.11	\$ 1,194.11	\$ 7,164.66		\$ 14,300.00	50%
KVIP		\$ 3,250.00					\$ 3,250.00		\$ 3,250.00	100%
Dial Security		\$ 892.52					\$ 892.52		\$ 900.00	99%
							Total Cell Tower Revenue	\$ 38,623.22		
Total	\$ 16,791.68	\$ 13,165.91	\$ 9,621.19	\$ 9,094.15	\$ 8,736.99	\$ 9,823.50				
YTD Total	\$ 16,791.68	\$ 29,957.59	\$ 39,578.78	\$ 48,672.93	\$ 57,409.92	\$ 67,233.42	\$ 67,233.42	\$ 67,233.42	\$ 146,075.38	46%

Basic Operating Expenses

Paid From TM Operations Fund by RRI

	Nov	Dec	Jan	Feb	Mar	Apr	Total	Budget	
Real Estate & Personal Property Taxes	\$ 1,700.00	\$ 1,700.00	\$ 1,700.00	\$ 1,700.00	\$ 1,700.00	\$ 1,700.00	\$ 10,200.00	\$ 19,300	53%
Timberlake License Fee			\$ 1,940.00				\$ 1,940.00	\$ 2,000	97%
Insurance	\$ 1,479.04	\$ 2,780.09	\$ 2,390.00	\$ 1,907.00	\$ 596.63	\$ 1,678.83	\$ 10,831.59	\$ 23,600	46%
Housekeeping & Gardening	\$ 18.32	\$ 25.96				\$ 5,300.00	\$ 5,344.28	\$ 12,000	45%
Cleaning & Maintenance Supplies	\$ 18.32						\$ 18.32		
Welding Tanks	\$ 57.66	\$ 57.66	\$ 57.66	\$ 998.15			\$ 1,171.13	\$ 2,300	51%
Garden Supplies								\$ 3,000	0%
Office	\$ 62.05	\$ 139.98					\$ 202.03	\$ 2,000	10%
Website & Social Media	\$ 193.13		\$ 51.96				\$ 245.09	\$ 750	33%
Computers	\$ 872.22			\$ 1,261.66	\$ 828.66	\$ 22.49	\$ 2,985.03	\$ 2,500	119%
Promotion								\$ 1,000	0%
Rail Bike Expense						\$ 1,223.88	\$ 1,223.88		
Misc									
Cat		\$ 46.33							
Bank Charges (checks & Safe Deposit Box)	\$ 286.09	\$ (14.10)	\$ 212.98	\$ 72.04	\$ 25.00	\$ 83.79	\$ 712.13	\$ 2,000	36%
Utilities									
Electricity	\$ 598.32		\$ 1,602.52	\$ 1,022.70	\$ 769.13	\$ 729.09	\$ 4,721.76	\$ 13,000	36%
Propane		\$ 1,958.69	\$ 406.49	\$ 2,544.46		\$ 1,264.50	\$ 6,174.14	\$ 16,000	39%
PortaPotty & Sanitation Services	\$ 385.00	\$ 245.20			\$ 60.00	\$ 438.75	\$ 1,128.95	\$ 5,000	23%
Garbage Service	\$ 227.12	\$ 227.12	\$ 227.12	\$ 227.12	\$ 227.12	\$ 227.12	\$ 1,362.72	\$ 2,000	68%
Phones & Broadband Access		\$ 437.04	\$ 437.08	\$ 406.43	\$ 466.46	\$ 352.61	\$ 2,099.62	\$ 5,000	42%
Permits, H2O tests									
--- Water Tests	\$ 35.00	\$ 80.00				\$ 35.00			
--- Haz Waste Fees		\$ 457.00							
--- DEQ Permit						\$ 828.00	\$ 1,435.00	\$ 1,000	144%
Fuel for Fuel Depot									
Repair & Maintenance				\$ 594.00		\$ 1,294.13	\$ 1,888.13		
Total	\$ 5,932.27	\$ 8,140.97	\$ 9,025.81	\$ 11,303.56	\$ 4,673.00	\$ 15,906.19	\$ 54,981.80	\$ 112,450	49%
YTD Total	\$ 5,932.27	\$ 14,073.24	\$ 23,099.05	\$ 34,402.61	\$ 39,075.61	\$ 54,981.80			



Train Mountain to be featured on KFLS Radio Talk Show

On Thursday May 30th, Train Mountain will be featured on the KFLS 1450 Klamath Talks radio show with Paul Hanson from 8:30am to 9:00am.

We will be talking about :

- The discharge of the IRS liens
- The K&W Rides starting Saturday 10:00-3:00pm
- Getting involved in the Train Mountain Railroad Club
 - Our new Rail Bike program
 - Upcoming Meets
 - Open Membership

That TM now is owned by a Public Benefit Non-Profit... and now that the public essentially owns TM....

we are looking for groups that want to use the property. We already work with

- Southern Oregon Horse and Carriage Club
- Union Pacific Railroad
- Hiking Groups

We want to get the property used more so if your group needs a place to meet or to hold an activity... please consider Train Mountain. 541-783-3030

Timberlake License

At this writing, we are working to schedule talks in mid June. Stay Tuned.

Disputed Equipment

Now that the IRS liens have been discharged, we want to resolve the disputed equipment issues with Ross Perrin and Sharon Breen. The next step is for Railroad Institute's attorney, Justin Throne to send them letters explaining what we need to do resolve the issues. We want to get these issues resolved. As soon as Ross's issues are resolved we look forward to Ross and Kay again being part of the Train Mountain Community.

Ties

We have no money for ties and track at this time, but we are thinking about how to buy the next load of Ties and Track.

Here are some facts :

- Ties are a big cost... 30 per track panel.... \$1.35 each in 2008 + freight
- Re-Cycled Plastic costs 70% of New Plastic.... rule of thumb
- Plastic has gone up at least 50% in price since we bought ties in 2007-2009
- If we could use less plastic, the ties would be cheaper.

Our TM 3"x2"x16" extruded recycled plastic ties use about 90 cu in of plastic (net of air)

We could move to an Injection Molded Tie... like a scaled up RMI tie. There are more miles of track on RMI ties than on any other tie in the hobby. People who use the RMI tie testify that the concave sides lock the tie into ballast and that the shape really holds the tie in place. This sketch shows one that would work for 7-1/4" or 7-1/2" track. We would have a smooth bottom. Injection molds can have inserts that allow them to produce slightly different products from a single mold.



When I took that tie to injection molders they did not like the thick areas of the tie. The thick areas would take a long time to cool and that would drive up cycle time in the mold which would drive up molding machine expense.

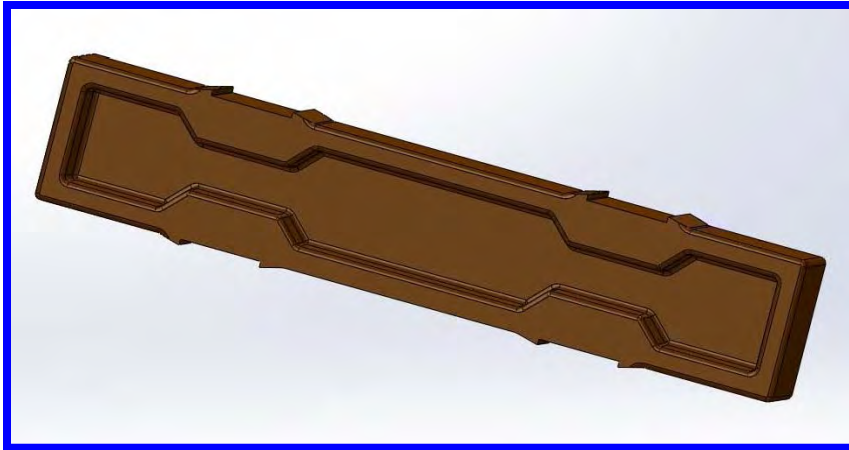

This tie is 60 cu in of plastic... about 55 cu in of plastic with a smooth bottom and screw blobs only on the top.

Injection Molders suggest a tie that looks like this :

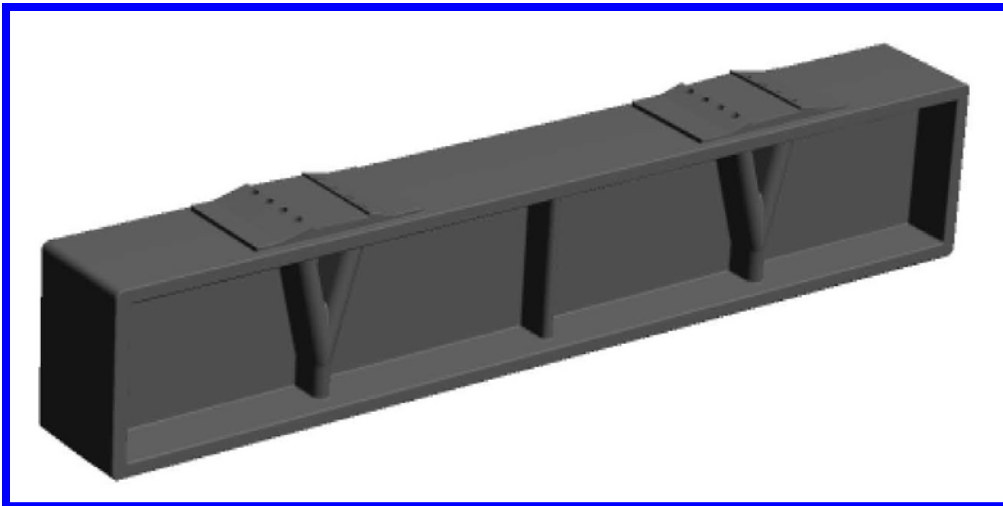

It is good from an injection molder's viewpoint since it has no thick blobs of material. It is about 1.149 lbs in weight, and about 35.73 cubic inches of plastic.

There are 4 screw positions on either side of the rail so if there are broken screws they can be replaced. The screws go in at the precise angle needed to sit flat against the rail. The metal tie plates are not needed. The mold can be built with inserts so some ties can have a different tie plate shape to be used where rail joiners are going to sit. Also 7.5" or 7.25" gauge ties can be produced. There is enough plastic strength to hold screws to hold marking washers and spring switch mechanisms. The tie would be textured except for smooth tie plates to look right.

Cu In Plastic	Tie	Pounds Tie Weight	Pounds Panel Weight
90	TM Extruded Tie	2.87	106
55	Scaled up RMI Tie	1.76	73
36	Injection Molders Tie	1.15	54
	Wood Tie	1.2	56

What do you think about these designs ?

Tax Lots 10 & 13

When Sharon Breen was running Train Mountain, she agreed to sell Bill and Rose Marie Dobbs 18.9 acres... Tax Lot 16 on the west side of Train Mountain.

Bill & Rose Dobbs plan to build track from Lot 16 to the Cooper Siding area to connect with Train Mountain. He has asked if Railroad Institute would be willing to sell Lots 10 and 13 so that he would have some neighbors that would help with the costs of bringing electricity to the area and building the track to Cooper Siding. The boards of Train Mountain Railroad and Railroad Institute are open to selling these lots if :

- The lots go to people who are or will be active in Train Mountain
- Railroad Institute keeps a right of first refusal when the property is sold
- A Conditional Use Permit can be obtained that will allow construction of a home.

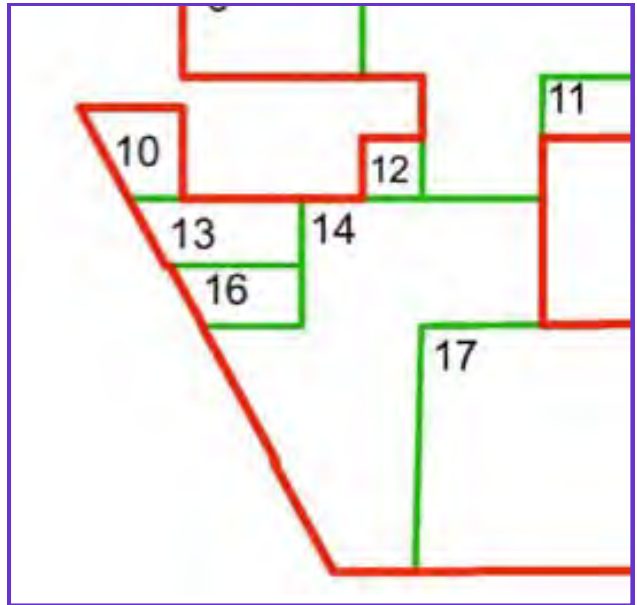

The Boards felt these lots are not essential to Train Mountain, they are an annual tax expense, and Train Mountain needs more people living at TM and actively involved in TM.

Railroad Institute has consulted with attorney Justin Throne and Klamath County. It is not clear that a Conditional Use Permit (CUP) for a home is possible on these lots, but it may be. Railroad Institute has decided that John Black and Justin Throne should work with the county to try to get CUPs. If the CUPs can be lined up, it is the intent of Railroad Institute to offer these lots for sale. No price has been set.

The proposed Bill Dobbs Track Plan is shown here to the right:

Railroad Institute is working to close the transaction with Bill and Rose by the end of May.

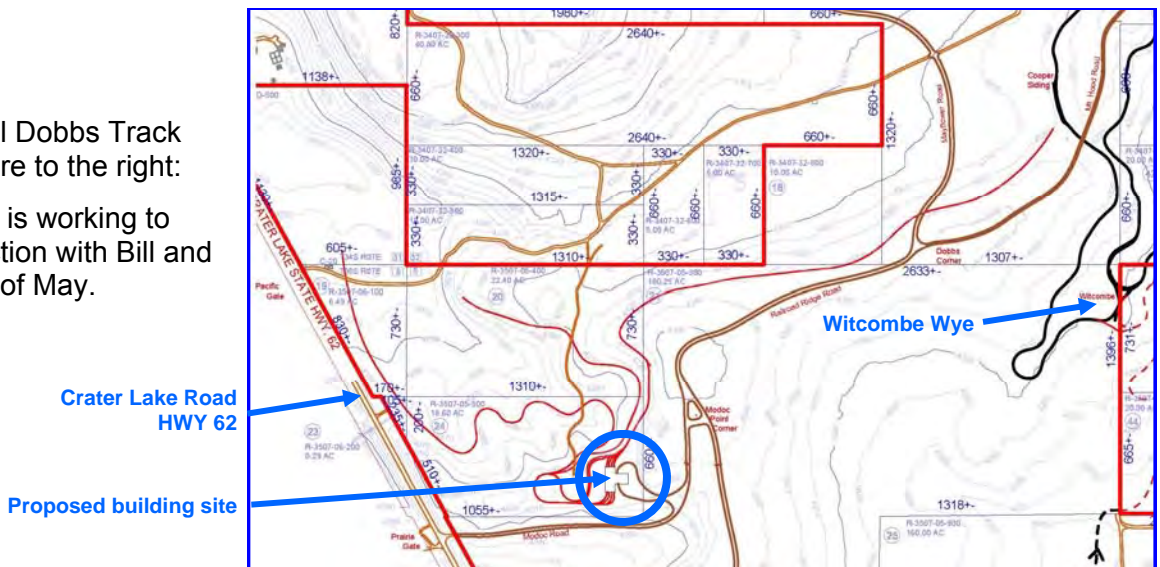

More Scheduled Events at Train Mountain / Klamath and Western

May 28th	Antique Truck Club	20 attendees
June 7th	Merrill Elementary	100 attendees
June 10th-11th	Mills School	100 each day (K&W event)
June 15th	Chiloquin Fire Dept Picnic	100 attendees

PHOTO GALLERY



Larry has been busy and so has Debra at cleaning the park up!



Ladies Day during the meets is always busy with all kinds of crafts.

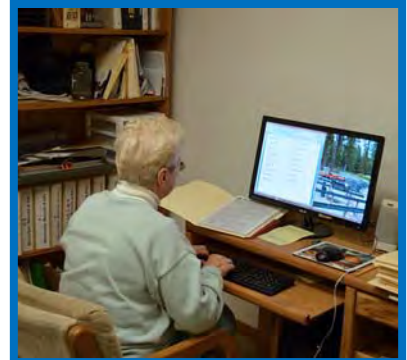

Dolores Bartholomew helping out in the office doing lots of filing and organizing!

2013 June Meet Event Schedule

Date	Time	Event	Location
Sat 5/25		Work Week Start	
Sat 5/25	10-3:00	K&W Public Run Day	K&W
Sun 5/26	10-3:00	K&W Public Run Day	K&W
Sun 5/26	6:00	Welcome Dinner	Central Station
Mon 5/27	8:30	Volunteer Meeting	Hall of Flags
Tue 5/28	8:30	Volunteer Meeting	Hall of Flags
Tue 5/28	6:00	Member Dinner	Central Station
Wed 5/29	8:30	Volunteer Meeting	Hall of Flags
Wed 5/29	6:00	Pizza Night	Central Station
Thu 5/30	8:30	Volunteer Meeting	Hall of Flags
Thu 5/30	10:30-3:00	Ladies Day	Hall of Flags
Fri 5/31		June Meet Start	
Sat 6/1	10-3:00	K&W Public Run Day	K&W
Sat 6/1	6:00	Member Pot Luck	Central Station
Sun 6/2	10-3:00	K&W Public Run Day	K&W
Sun 6/2		June Meet Ends	



Daffodils in bloom during a meet! They are usually gone by the first meet but not this year!



The annual gathering of the narrow gaugers always brings out lots of really neat stuff!



Like I said - lots of really neat stuff!

PHOTO GALLERY

CONTINUED



Narrow gauge engines are really big! Cool!



How about getting a REAL cab ride! Now that's rail-roading eh!



Timber tunnel on the Klamath and Western



Lots of things were in full bloom and some members enjoying the sunshine.



Up close and personal, looking good!



In between snow storms and hail and rain, spring has sprung at Train Mountain.



The logging camp saw some action during the NG Meet.

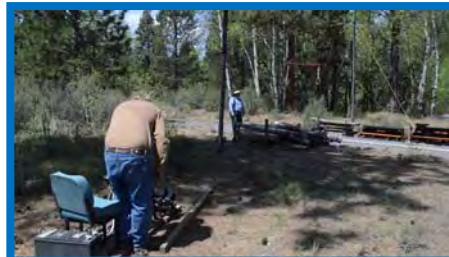

Loading the logs onto the rail-cars takes a little practice and is a lot of fun.



O! number 9 taking a break from all of the action during the meet.



Moving all of the wooden tied track panels from Canada to Containerville was a very nice looooooong train with lots and lots of cars and track panels. These should be enough to finish the front containers.

SOLID DESIGN

2 1/2 inch scale EBT Hoppers



\$3750 for #882



\$3500 for #954

As advertised in Live Steam Magazine

Call Adam @ 989-330-6663

Currently at Train Mountain
See Bill Dobbs for info



Did you see the great article and front cover story from the January /February 2013 issue of Live Steam and Outdoor Railroading? It is a most complimentary article about the facility and the great gang of folks that hang around the place and put on terrific live steam train meets. Pretty cool!

The terrific video that Aaron Bentsen from 7Idea Productions shot at the 2012 Triennial is now available through the main office at Train Mountain. Give them a call at 541-783-3030 and get your on the way to your place. It's \$30 for the video and \$3 shipping and handling lower 48, \$4 S&H for all others. A most enjoyable video shot by a true video artist and of course our favorite subject, Train Mountain!

Our good friend Jim over at Discover Live Steam has also placed an ad for us on his terrific website, thanks Jim.

www.discoverlivesteam.com

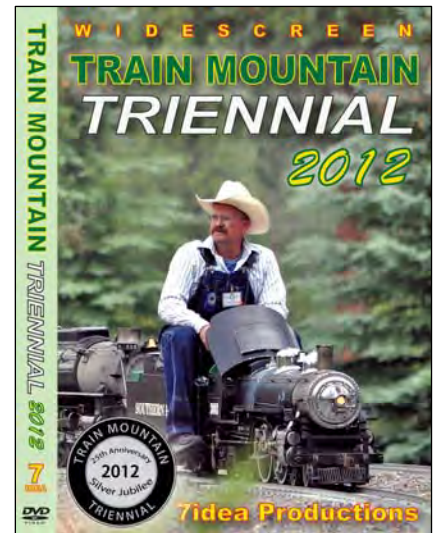

HAVE SOMETHING YOU WANT TO SELL?

Place an ad in the Gazette!

1/8 Page: \$25/month or \$250/year

1/4 Page: \$40/month or \$400/year

1/2 Page: \$70/month or \$700/year

Full Page: \$125/month or \$1250/year

Published by **Train Mountain Railroad**
P.O. Box 438
Chiloquin, OR 97624
Email: info@tmrr.org Phone: 541-783-3030

Editor:
Russ Wood - russ@hobby-tronics.com
Contributors:
TMRR BOD, Friends
Photos:
Tom Watson