



The Mountain GAZETTE

© 2021, Train Mountain

An Official Publication of the Train Mountain Institute and TM Railroad—Issue Vol. #4 Issue #37 **September 2021**

September

When starting each issue of the Gazette, I sometimes have a day or two of what's called "writers block" Well this issue does NOT fall into that category! We have so much content coming from all over the campus that my job is simply a matter of gathering and formatting this month, so not much writing or editorial comment needed.

Big Build is over and what an awesome work week and a wonderful bunch of volunteers we had! The project for this year was to see if we could finish the replacement of the wood tie track on the Rio Grande subdivision. Well folks it's done! They relayed, ballasted, and tuned approximately 2,380 feet of track including a few switches, and I might add it runs terrific! They even had time to sneak up the hill to Crane Siding and did some work up there too!

Additionally three more of the remote switch stands were installed. More track right of way cleanup was done.

The TMRR BOD had their annual meeting and the results of that meeting is outlined in another article in this issue.

The 2022 Triennial Steering Committee also had several meetings in the afternoons after the track work was done for the day. The results of those meetings will start to show up in additional articles in this and future Gazette issues.

Also in this issue is an announcement of an "Unofficial Work Week" just before the Fall Colors meet.

The next important announcement is that we hope to open the Online Registration for the 2022 Triennial starting on October 1st. The number (10) on the bottom of this page is the number of months we have to prepare for this really big event but the registration starts in just a few days.

We want this to be a really fun event and we also want to try and keep the "stress level" to a minimum. So please be patient with us and your fellow volunteer members as we get ready for the Big Event!

Enjoy all of the content from this issue (there's a lot)!

2022 Train Mountain Triennial
June 11 - 19 Work Week June 20 - 26 Meet

10
And
Counting

Please Volunteer at a Train Mountain Meet!

Register or Join - https://trainmtn.org/tmrrmembers/Member_Portal.aspx

New Board Member TMI and FTM

By: Jerry Crane

The Board of Directors of Train Mountain Institute and Friends of Train Mountain are happy to announce the election of a new Board member. David Waterstreet is joining the two Boards and will serve as Treasurer in both organizations. David is filling the vacant position left by the passing of Carl Vanderspek last winter.



From The Desk of The President of Train Mountain Railroad September 2021

By Jeff Mills

September was busy with the Big Build Meet. The Track Shop, led by Dennis Ward, has been busy all year producing track panels to finish the Rio Grande Division. Most of these panels were used by the track laying crew led by Mark Flitton to complete the Rio Grande Division track replacement. This was accomplished in two phases. First phase was from the South Portal Circle to the Saanach Siding and the second phase was from Saanach to Lillyville. The track is now upgraded to steel rail on plastic ties, replacing aluminum rail on wooden ties. That old track was in an extremely degraded condition and the screws no longer held the rail in gauge from ultraviolet damage. That just leaves Lucky North and Sharon's Short Cut to be replaced. Also, there are a few short sections in other areas left to be replaced. This project nears completion of our mandate to upgrade all the main line track. It will also make the running of the 2022 Triennial much more enjoyable.



The Train Mountain Board has seated two new members, Richard Croll and Pete Robbins, to begin their 3-year terms. These new board members should be known to most of the members as Richard Croll has been Train Master and Committee Chair for the OPS meet. Pete Robbins has been a top operator at the last few OPS meets. David Waterstreet has resigned from the Train Mountain Railroad Board to take a position on the TMI Board. He served 6 years as TMRR Treasurer and will be missed on that Board. His replacement is Clay Smith who will be taking over those duties.

There was plenty of additional work done on the Railroad during this Big Build. A hard working and determined crew went out and restored the Crane Station Siding to service. This crew was led by Courtney and Amy Jones of Hobart Car and Foundry. Courtney's group were the ones responsible for the construction of the Crane Water tower and Crane Station. A big thanks goes to them for digging it out from the mudslide last month and releveling of track and the switch at the north end of the siding.



The Triennial is quickly approaching, and registration is on track to start on October 1st. It is important to register early for this event for a number of reasons. First, the price will increase as it gets closer to that Meet. Secondly, early registration helps us by getting start up money in the treasury. We need to make equipment and supply purchases.

Cont. Next page:

Please Volunteer at a Train Mountain Meet!

Register or Join - https://trainmtn.org/tmrrmembers/Member_Portal.aspx

Cont. from previous page:

As many of you have noticed, lead times on many items have increased in the last year so we must get an early start on these purchases. We must commit to service contracts with various contractors which require prepayment or deposits.

Finally, your registration will kick-off e-mails to provide essential information in advance of your arrival. Instructions regarding your equipment, camping, and more will be sent to prepare you for the Triennial. Please take the time to read this correspondence. The website will also have links to this information as we prepare for this long awaited event.

The 2022 meet schedule is now on the website. I am looking for volunteer coordinators for the 2022 Meets. This is a rewarding and important position for each meet. Jordon Dobson stepped up and handled 2 meets this year. Train Mountain desperately needs more members to fill these positions in the future. They provide valuable experience to members who can then fill future Triennial Leadership positions.

Up next is the Fall Colors Meet. There is not a scheduled work week. However, we encourage any who could come early to help us winterize the Park. There is always a lot to be done and we can find work for all who can show up.

September (Big Build) Report

An article by Dennis Ward—Track Superintendent

Wow! I started last month's article with wow. This month calls for another WOW. The September Meet is also known as the Big Build. This September was no exception. The Idaho Mafia crew, led by Mark Flitton, managed to remove over 2,300 feet of aluminum track with wooden ties. They replaced that track with steel rail on plastic ties, re-ballasted the entire 2,300 feet, then managed to get it all tuned for smooth running. The project also called for the replacement of four switches (that's "points" for our Australian friends).

Ballast trains, consisting of three ballast cars each, were run by Jim Armstrong, Jim Henry, Dick Miller and myself. Loaded ballast cars weigh about one ton each. Each car load covered approximately 50 feet of track.

The WOW continues, Jeff Mills and crew reconnected the remote switch controller at Saanich siding. The switch allows the train crew to select either Sharon's Shortcut or Rio Grande loop. Jeff and his crew also added remote switch stands at Clyde siding in the Hope division, Weaver siding in the Firewood loop, and at the entrance to Youngstown yard. A remote switch controller was previously installed at Youngstown which allows the crews to choose whether to go left to Dogwalk or right to continue up the Serpentine.

Since the August report Dale Furseth moved one of the Youngstown yard switches which shortened one of the two yard tracks. This was done to provide clearance for the previously installed Dogwalk/Serpentine remote switch controller.

There are approximately 1,740 feet of aluminum rail on wooden ties remaining on main track. This includes Sharon's Shortcut (550'), the track from Midway circle to Red Ant junction (950'), and the connector between these two routes (240'). Four switches will also need replacing. The plan is for the local track crews to get this all done before next year's Triennial. We are awaiting the arrival of tie material to rebuild our track inventory. We expect the plastic tie material next week at which time track production will resume.

In the meantime Robert Stevens and Ron Green are in the process of disassembling the old track which was removed from the Rio Grande loop. We would love to see all of this material recycled. Wood ties, used tie plates, screws and rail joiners are free and can be picked up at the Track Shop. Used aluminum rail is for sale at Train Mountain.

2022 Triennial Committee Chairpersons as of September 2021

Triennial Co Chairs

As we approach the 2022 Triennial, we only have **seven** Committee Chair **Positions open**. We need to get these filled as soon as possible to continue planning for the 2022 Triennial. We will provide detailed job descriptions of each Chair's responsibilities and those of their respective committee volunteers. You won't be walking into any of these spots blind!

These are important positions which keep the Triennial running smooth and provide our members and visitors the greatest experience in scale railroading. If we do not have members volunteer for these listed positions, we would be forced to assign them.

The open chairs are:

Arrival/Check in

South Meadow Campground Host

Parking

Security

Shuttle Vans/ Golf Carts

Post Triennial Clean up

First Aid (need a nurse or para medic for this one)

Being a Committee Chair is a rewarding experience. It is ***not the chair's duty to do all the work!*** Supervising and training your committee volunteers is your main goal. You do need to recruit volunteers to fill 2 hour shifts throughout the day. The Triennial Office is an important tool in that process. Those volunteers maintain the sign-up lists for each committee during both weeks of the event. So, you won't be alone in this process!

Please consider one of these positions and contact me with any questions or concerns. Jeff Mills, via e-mail at oldcatd399@hotmail.com or cell number on the **back of** your meet name **badges**.

2022 Train Mountain Triennial
June 11 - 19 Work Week June 20 - 26 Meet

The current list of Chairpersons

Committee	Volunteer
Arrival Ck in	
Back Shop	Woody Lewis
Camp Grnd Host 6 Acre	Peter Wood
Camp Grnd Host Blue Caboose	Kevin Sherer
Camp Grnd Host South Meadow	
Carpentry Shop	Bill Kludt
Communications	Dick Miller
Equipment Maintaince	Richard Cox
Engine Shuttle	Karl Klontz
Fire Safety equipment	Jeff Mills
First Aid	
Fuel Yard	Ed Ackerman
Garden Railroad	Denny Ediger
Infrasturture Repair	Jerry Crane
Library/Infromation	Sabra Rickman
Packet Preparation	Pam Willaims
Program	Russ Wood/ Pam Williams
Parking	
Safety Video Viewing	Kirk Devine
Security	
Shuttle vans / golf carts	
Signal Maintenance	John Cooper
Steam Engine Safety Inspection	Ken Olsen
Track Repair mobile North	Joe Simon
Track Repair mobile South	Mark Flitton
Track Assigment	Dean Willoughby
Train Inspection	Jeff Pape
Trash Pick up	Jim Moore
Train Game	Steve Eddy
Train Shuttle	David Savage
Triennial Office	Pam Williams
Triennial Dvd	Aaron Bentsen
Unloading/ loading /Staging	Ken Burns
Vendors	Russ Wood
Website	Tom Watson
Yard Master Main Yard	Richard Croll
Yard Master Central Station Yrd	John Cooper
Post Triennial Clean up	

From The Signal Maintainers

By John Cooper and David Waterstreet

Much progress was made on signal projects during the Big Build meet. Dave's friend, Nate Upperman finished and delivered a new crossing flasher circuit board. We anticipate his design will be used to upgrade all flashers at TM. The first board was tested at the six-acre campground crossing between Grand Junction and Debra's Corner where the conduit and wiring had been finished at the last meet. After installing a few insulated joints in the rails, the test was successful. The board detected approaching trains and the LEDs flashed brightly. Nate programmed the board so that the LEDs reach full brightness gradually when they turn on, and taper gradually to dark when they turn off. This is to imitate the behavior of incandescent bulbs. Unfortunately, the algorithm that Nate used didn't quite capture the aesthetic we were hoping for. The turn-on happened quicker than the turn-off, so it appeared for an instant that both lights were on. Dave is going to ask Nate to revisit the dimming feature and hopefully we will have the project complete at the next meet.

Progress was also made this week on the Pennsylvania position-light signal project. Early in the week we were able to get the central hub of the signal (which we've been referring to as the "spider") hoisted and mounted up on the mast. Luke Connor connected tie-downs to the top of the mast and used the ratchetting feature to raise the unit a few inches. He would lift the unit with two of the tie-downs, and then transfer the weight to the other two tie-downs. By alternating and repositioning between the sets of tie-downs, we didn't need any additional heavy equipment to get the heavy hub into position.

Later in the week, we used the man lift to attach each of the lamps to the hub, and then attach the hoods to the lamps. The top head of the signal has a total of seven lamps and weighs hundreds of pounds. This signal will also have a lower arm, so a mounting bracket was fabricated to hold three more lamps further down the mast. Stay tuned for a future article describing what the signal is indicating when the various lamps are lit. *(Ed. Note: How come the young guy is in the bucket?)*

After the hardware was in place, we began the wiring on the signal. Wiring to all of the lamps was completed and the control board was mounted in the equipment box at the base of the mast. We had a successful brief test of the control board and lamps, but permanent wiring for the power supply and connections to the rails still needs to be done. The face plate of the signal also needs to be installed after we complete some minor metal work and painting.

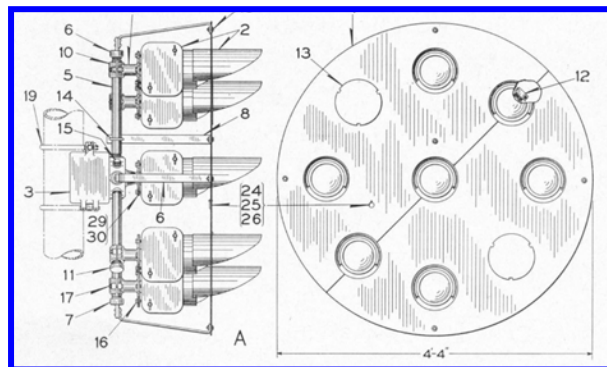

The TrainGame Reaches Beta Test

An Article by Steve Eddy

It has been a couple of months since I last reported on the TrainGame and the progress has been sensational. We reached beta test ahead of schedule and the cars have already surpassed 70 movements in just a few weeks. We currently have 7 test cars on the layout and the website development is progressing at a stellar rate. The first test cars were placed for free movement meaning that the central computer system was only tracking them but not dispatching. If you see a car on the layout you may move it to another location. We ask only that you leave it on a stub or siding that will allow a couple of hours of sunshine a day to keep the transponders going.



The initial cars were stock TMRR cars like the one above. As of the beginning of the Big Build Meet we have added the first two member owned cars. Keep in mind that car owners earn movement credit the same as the movers of the cars. The credits known as TG\$ are calculated based on the distance moved, per Diem rates of both the origination and destination locations and/or industries, as well as weight and load. Member-owned cars can also include incentive points added to the move value to try to persuade movers to move their cars.

The website has grown in leaps and bounds under the guidance of Nathan McConnell who by the way is the designer of our Transponders. While even in Beta Test mode Nathan has made the website available to members in order to watch the development as well as allow car movements and tracking. Here is a screenshot of the current rolling stock screen showing the car names, location and update time. From here, one can select either the car which will be displayed or the station which will narrow down its location as well show a photo of the station.

The website is designed to display equally whether on a large or small mobile device screen. A player can access the system from a cell phone, tablet, or computer. There will be a kiosk available where movements can be selected by those that don't have a smart device.

THE TRAIN GAME					
Map		Rolling Stock		Moves	
Car list					
db#	Type	Location			
CP334776	Gondola	Elizabeth (90ft)	12:25	9-14-21	29
SP246081	Box	Blue Caboose (69ft)	18:02	9-14-21	30
TMR504	Flat	Robinson (40ft)	19:39	9-13-21	24
TMR505	Flat	Crane (185ft)	13:03	9-14-21	28
TMR801	Flat log	Central Station (121ft)	18:02	9-14-21	25
TMR2119	Gondola	Klamath & Western (110ft)	18:01	9-14-21	27
TMR2131	Gondola	Robinson (46ft)	13:03	9-14-21	26

Register or Join - https://trainmtn.org/tmrrmembers/Member_Portal.aspx

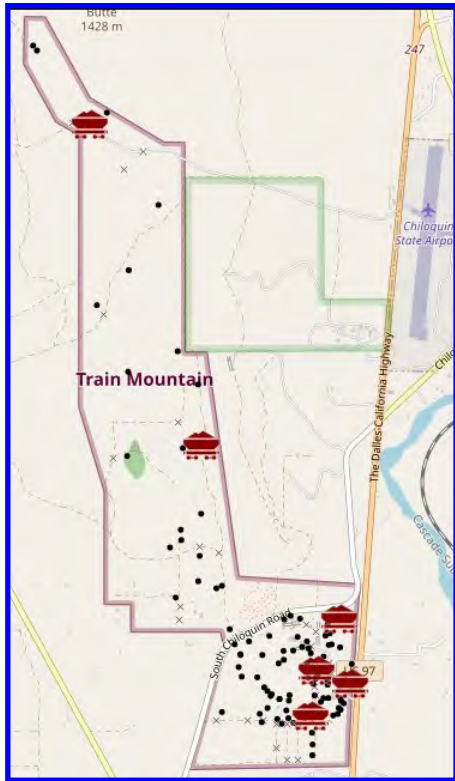

The Map screen shows the TM map and the locations of the cars. From the Map you may select, view and request movement of the specific car or cars. Selection of a car allows viewing a picture and displaying its statistics and telemetry.

The Moves tab allows selection of calculated moves of the selected car to a destination defined by the industry supported by the move.

Available Jobs			
Car Name	Pickup	Set out	
! TMR2131 Gondola	Robinson Z:2	Blue Mountain Z:1	Select Job
! CP334776 Gondola	Elizabeth Z:3	Coral Z:1	Select Job
! SP246081 Box	Blue Caboose Z:1	Central Station Z:0	Select Job
! TMR505 Flat	Crane Z:4	Appendix Z:2	Select Job
TMR504 Flat	Robinson Z:2	Main Yard Z:0	Select Job

0.00473

The first release of the website will offer access for train car movements, Maintenance of Way project assignments and TrainGame administrative maintenance tasks. All of these facilities will offer points accruing in the form of TG\$ to be used within the game.

As I said before, the TrainGame website will be made available to any members interested in following the development as well as those who will help with testing and certification of the TG system. If you are interested please contact sceddy@charter.net for the website url and basic instruction for creating an account. Please be aware that the website will be constantly changing as features are added to the programs.

Transponders

The transponders are the heart of the system and are being tested daily. The reliability of the devices has reached completely acceptable levels over the last couple of months. The transponder is in each car participating in the TG and uses radio signals to communicate with the central computer system.

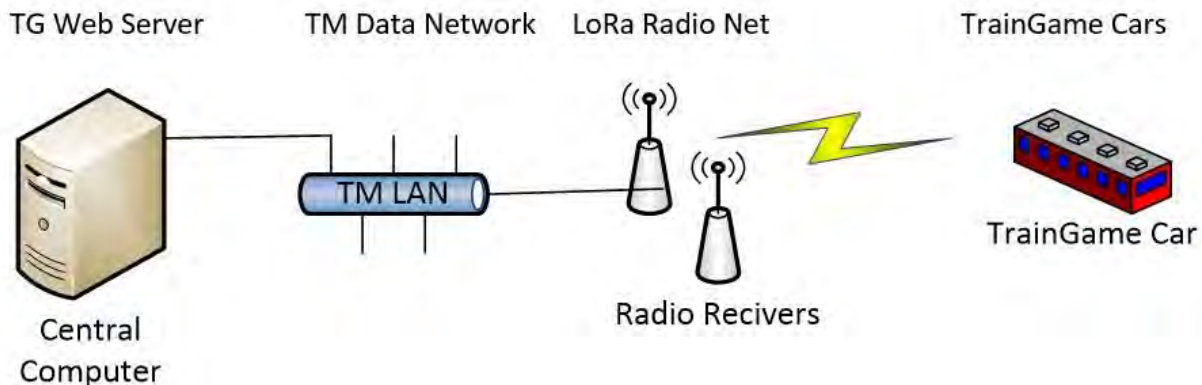



In order to cover the 2300 acres and 37 miles of track at Train Mountain we need multiple radio receivers strategically placed on the property. We are currently enhancing these facilities. The picture below taken today (9/14/21) shows one of our major projects that will enhance not only the TrainGame communications but also our two way radio communications across the property. The new facility adds critical equipment to the south end of Caboose Ridge. Our hats are off to Richard Cox and Luke Connor for putting the new tower up in a matter of hours. The TrainGame team will now install the radio equipment and antennas in the next few days. Note the signal cabinet that will be used for the electronic equipment. In the background is Steiger Butte on the Northern end of the property.

The goal of the TrainGame is to combine a fun operating environment that simulates real railroad movement scenarios and offers members tasks and goals to enhance the Train Mountain experience and an Operational Support System to provide documentation, inventory and task management facilities to help proceduralized daily operations and maintenance in support of our volunteer workers.

2022 Triennial Meet Fees Schedule

Beginning:	Through:	Individual: 18 and up	*Family: 2 Adults & Children under 11	**Family Max: 2 Adults + Teens under 22
1-Oct-2021	31-Dec-2021	\$75	\$140	\$220
1-Jan-2021	31-Mar-2022	\$90	\$170	\$260
1-Apr-2022	31-May-2022	\$120	\$220	\$320
After June 1st, 2022		\$150	\$300	\$400

* Family: All immediate family members (adult = husband, wife, son, daughter, spouses to sons/daughters and guardianships over 18) plus all children and grandchildren under 11 years.

** Family Max: Family as described above plus teens (11-17) and family college students thru age 22.

Unofficial Work Week—Fall Colors

Matt Thomas

Have you been looking for a reason to come out to train Mountain? We could definitely use your help.

The “unofficial” Fall Colors work week is fast approaching. We are calling the project “Kicking ASS-pen”. I was able to take a tour of Aspen Grove last weekend with Dale to plan what needs to be done. Dale and Bill Shepard have been hard at work for the last 2 months working almost daily to prep for this project. The photos attached will show how much work they have done, its mind blowing.

Dale and Bill have cut the dead trees and removed everything for us. Our job will be to pile up what they have cut and removed and move it to brush piles. The location of the brush piles will be well marked and most of the times very close to where the wood and debris are located. We will not rake up anything. This is a drag/carry stuff to the piles only. This is a LARGE area that will need to be cleaned up. We may section the work areas by day so we don't get overwhelmed and know what area to work in.

We will start the project on Sunday, October 3rd and work daily until it is done. We do not have set hours but usually try and start at 8:30 and work until lunch time or so. I plan to eat lunch at Potbelly Deli on most days and all are welcome to join us. We want everyone to have fun after the work to remember why we are doing this work on our railroad. We plan to drive to work location to save time. This will also allow us to not close down a section of track. As we get closer I will post times we will leave from Central Station so you can follow us. Of course you can run your train out if you want but please park at Beauchamp siding and not block the main. We will be parking in the same area. With the scenic loss of Hope Circle, Aspen Grove Loop is one of the most viewed areas at Train Mountain. This project is only the beginning of the maintenance program for the Grove. The work that has been done already has made a HUGE difference to the look and health of the area.

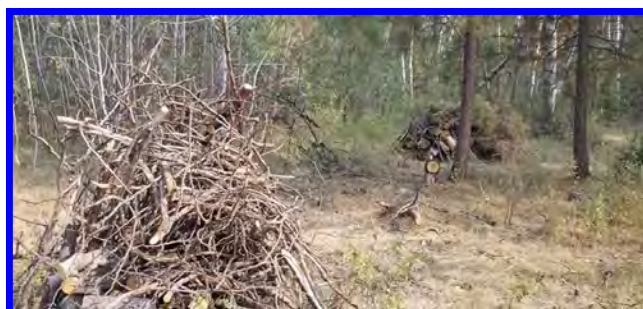

Cont. next page

Cont. from previous page

Dale's list of recommended survival items:

- Boots with good ankle support
- Long pants
- Thick gloves
- Band Aids (I will have a basic first aid kit on site)
- Water/Gatorade etc. (We will have a large water jug on site for refills.)
- Snacks
- Cold weather gear as needed

The area has a large amount of wild roses with barbed type thorns, these are not easy to see among the foliage and do not feel good when they snag you, ask me how I know...

I want to thank Dale and Bill for all their hard work making our jobs that much easier. I also want to thank all of you that come out and help at these almost unrecognized events, we appreciate it, Train Mountain appreciates it and all the visitors that will be visiting certainly will appreciate it.

Please respond to this post with if you can make it, what day you will arrive and how many days you will be there. We will have jobs for all types of abilities; please don't think you can't help, trust me you can. Have friends that want to help? Invite them out (Train Mountain membership is not required unless they want to bring their own train)

We look forward to seeing and working with you all soon!

Why I Want/Need to be a Triennial Vendor

Russ Wood

This is a funny sort of article but I think it's very important. My hope is that you as members who are planning to come to the Triennial will pass this information on to your favorite vendors.

Attending vendors need to be reminded that those who attend also represent their local clubs and groups of live steam enthusiasts. 2018 saw members from 44 states and 11 countries. Sales may not be brisk during the event but experience has shown that those who were introduced to products at past Triennials eventually became customers of those products. Most attendees will have fully loaded vehicles just to get to the event and may not have room for that new box car or caboose or whatever. BUT when they get home and have that van or trailer empty!

So make sure that you remind your vendors that they need to bring lots of handouts, price sheets, signup sheets for those reservations for future deliveries, etc. Anyhow you get the picture. This is *their* opportunity to meet *their* customers face to face and spend some quality time with them. We already have a few vendors just waiting for the registration to begin.

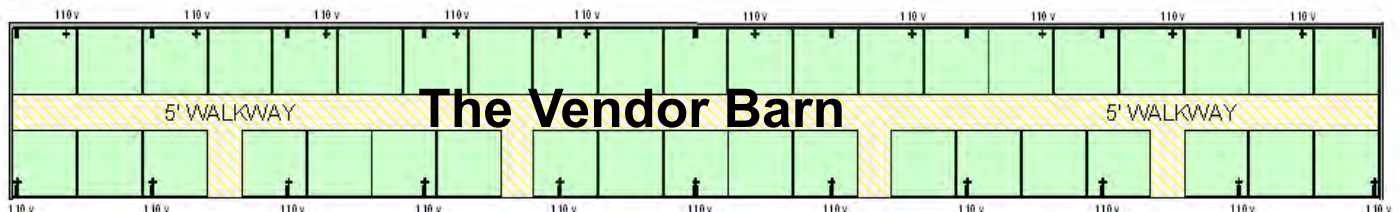

2022 Triennial Camping Procedures

Pam Williams

Because of the expected large number of campers the usual Train Mountain campground procedures and policies have been amended for the 2022 Triennial.

If you plan on camping or RV'ing at Train Mountain for the event please review these new procedures **BEFORE** you Register for the event.

Train Mountain will have only two designated member camping areas for attendees, Six Acre and South Meadow. They are both dry-camp areas with NO power or septic. There are water fixtures located around the areas, but not for hook-ups. There are NO black water dump stations and only two grey water dump canisters available. Camping will only be permitted in the designated areas. A single vehicle Parking Tag will be provided for each Camping Area.

Six Acre is located near the front gate and is for tents only for this Event. Tent Trailers, small trailers and wheeled campers must use South Meadow for the Triennial. ONLY Six-Acre campers will be allowed to enter the Park through the Front Gate during the entire 2-week event. You must have your designated Six Acre Parking Tag visible to enter through that gate. Without it, you will be directed to enter through Katy Lane gate.

South Meadow is located along Katy Lane in the southern area of Train Mountain. All "wheeled" camping equipment, including pop-ups, camper trucks or vans, will be directed to camp in the South Meadow area. Everyone attempting to park in South Meadow must do so with instructions from a South Meadow Host or their assigned volunteers. If you are camped in South Meadow, you will follow the designated Molly Lane exit route to depart via the Katy Lane gate.

For the Triennial Katy Lane and Molly Lane are both single direction roads. Katy Lane runs West to East and up to Central Station. Molly Lane runs East to West and exits via the Katy Lane Gate.

Blue Caboose will be designated for use by Triennial Committee Chairpersons ONLY during both the Work Week and the Triennial Week.

CAMPGROUND HOSTS:

All 3 of our Camping areas will have designated Hosts. Host sites will be marked with a sign indicating them by name. Hosts oversee their respective area but will have access to management to deal with issues not resolved on site. Campground Hosts are working from instructions from the Triennial Committee, if you have an issue with the procedures please feel free to contact one of the Triennial Co Chairs. Their contact information will be on the back of your Meet Registration Badge.

Hosts will direct all arrivals to their appropriate site and their instructions are required to avoid overcrowding or wasted areas.

We expect to have every camping area completely FULL by the middle of this Event so cooperation with your Host's instructions is essential.

Detailed information about using our Camping facilities will follow once you are registered and again when you check-in for the 2022 Triennial!

Greetings from Joyce at the front office:

Exactly the next day after I wrote last month's article mentioning the unrelenting ninety plus degree heat, it was sixty six degrees! It stayed cool for a few days and then warmed back up into the seventies and eighties. We had a nice rain last week that helped clear the air. It is great to see in the distance and to view blue skies again! We may be getting some more rain this weekend so hopefully that will help keep the air clear.

There was less attendance at the Build Build work week and meet than usual, but there was still a nice turn out and lots of fun. Much fast and hard work got done on the tracks at Rio Grande and other volunteers worked on trimming and clearing brush up north at Aspen Grove.

The smoke filled air made for a large number of Harvest Hosts cancellations and held some visitors away over the past month, but both did also continued to come in.

Charlie, the cat, is spending more time indoors in the office as the morning temperatures get colder. He likes to guard the donation box and continues to greet members and visitors. Maggie spends most of her time in the Hall of Flags. She helps to keep the Hall free of critters and provides company to Raven and a volunteer or two.

If you lost, misplaced or just plain forgot a bicycle at Train Mountain, please call the office and describe it. We would like to find its owner and get it back to them.

Train Mountain is presently at 422 memberships and 759 total members for 2021. We will start taking 2022 renewals and new 2022 memberships starting on October 1st.

Lots of planning and preparation for the 2022 Triennial is occurring. You will be able to register for the Triennial meet starting also on October 1st.

We are saddened to learn that Daniel Ode passed away a few days ago. He was an active volunteer and had very recently started doing rail tours for Train Mountain visitors. He will be missed.

If you volunteer, please be sure to complete a volunteer hours form and to turn it in to the office. As an alternative, you can report your volunteer hours online by going to the Train Mountain Railroad website. If you need help logging in as a member, please let me know and I may be able to help you.

We presently do not have a functioning bulk email system. If you are reading this, please let other TM members know they can access the monthly Gazettes by clicking on the link below or by going to TMRR home page and clicking on the button for the **Train Mtn Gazette**. <https://trainmtn.org/tmrr/index.shtml>

Coming October 8th and lasting through October 12th is the 2021 Fall Colors meet. We are looking forward to seeing all who will be attending!

Stay safe and be well!

2021 Train Mountain Train Meet Schedule

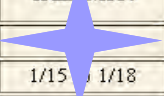
	Polar Bear Train Meet	Spring Awakening Train Meet	Narrow Gauge Train Meet	Operations Train Meet	August Train Meet	Big Build Train Meet	Fall Colors Train Meet
Work Week							none
Meet	1/15 to 1/18	5/7 to 5/9	5/28 to 5/30	6/24 to 6/27	7/30 to 8/1	9/10 to 9/12	10/8 to 10/12

CLASSIFIEDS

2018 Triennial Video Now Available

The 2018 Train Mountain Triennial video from Aaron Benson at 7Idea Productions is now available. You can order online at the link shown or you can call the office at 541-783-3030 to get your copy. This is a most enjoyable video created by a true video artist and of course it just happens to be about our most favorite subject! The cost of the video is just \$29.95, quite a bargain!

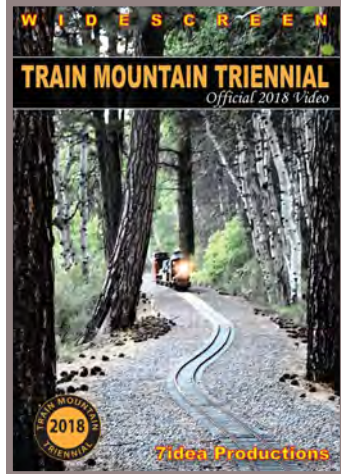

Our good friend Jim over at Discover Live Steam has placed ads for us on his terrific website, thanks Jim. discoverlivesteam.com

Did you see the great article and front cover story from the January / February 2019 issue of Live Steam and Outdoor Railroading? It is a great article covering the 2018 Triennial. and the great gang of folks that hang around the place and put on terrific live steam trainmeets. As an added bonus there is a photo album by member Michelle Moore! How about that! Pretty cool!

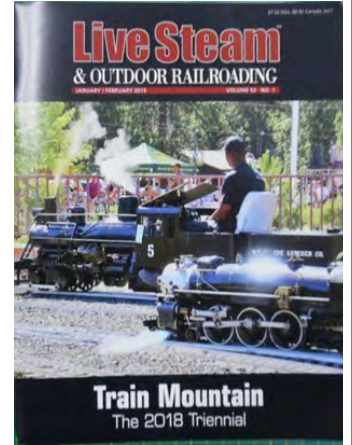

Crater Lake/ Train Mountain Vacation Rentals

Crater Lake Chalet

Located on Hwy 422, only 1 mile off Hwy 62 and 2 miles from Hwy 97 in the Chiloquin area. This house is at north end of Train Mountain and contiguous to Train Mountain.



This comfortable house sits on 35 beautiful acres. 2 bedrooms and 2 bathrooms. Can sleep up to 6 people.

Panoramic View Ranch House / Crater Lake

This ranch house is located on Hwy 62, and attaches to the west side of Train Mountain. The 56 acres, panoramic views of Agency Lake and



the Cascades. Enjoy a peaceful and private experience. 4 bedrooms and 2 bathrooms. Can sleep up to 8 people.

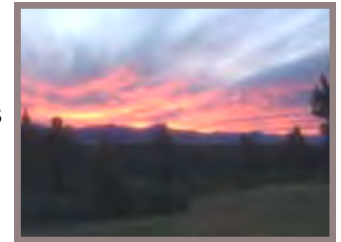

For more information please call: **Julie 415-756-3943** or **Mike 415-420-9026**
10% off for train mountain members

CLASSIFIEDS

THE POTBELLY CAFE



Located only 1.5 miles off Hwy 97 in Downtown Chiloquin in the same building as the Post Office 212 1st Ave-



Good Service
Good Food
Friendly Folks



Crater Lake Junction Travel Center

34005 Hwy 97 N, Chiloquin, OR 97624, 541-783-9800

The Crater Lake Junction Travel Center opened for business in 2010, and is owned by the Klamath, Modoc and Yahooskin Tribes. Open 24 hours a day and located just next door to Kla-Mo-Ya Casino as you enter, this travel center offers competitive fuel prices and many convenience items. Travelers can fuel up with gas, diesel, or propane. Stop in for a snack or soda, or grab a quick meal featuring food to go or you can eat it there, Free Wi-Fi, a comfortable lounge with large screen TVs, laundry and shower facilities, and ATMs are all available.

WE ARE ALL VOLUNTEERS
DON'T YELL AT ME, I AM A VOLUNTEER!

HAVE SOMETHING YOU WANT TO SELL?

Place an ad in the Gazette!
1/8 Page: \$25/month or \$250/year
1/4 Page: \$40/month or \$400/year
1/2 Page: \$70/month or \$700/year
Full Page: \$125/month or \$1250/year

Published by Train Mountain Railroad
P.O. Box 438
Chiloquin, OR 97624
Email: info@tmrr.org Phone: 541-783-3030

Contributors: TMRR BOD, Friends, TMI
Photos: Tom Watson



Please submit your volunteer hours. If you work off site or at home on Train Mountain projects - these hours count.



REMEMBER: No job is complete without the paperwork!

I AM NOT A ROBOT!

There have been a few changes made to the member's site, specifically where payment information is entered. The most noticeable change is that we have added a question asking if you are a robot. You check the box and depending on a bunch of things, you may be asked to choose from a set of pictures. You may be asked to click the pictures that show street signs, or click on pictures that show store fronts. It seems silly, but the questions and challenges are carefully crafted and updated by Google, and have an amazing success rate at determining if the entity pressing the keys is a real person or a computer program ("robot") trying to gain access.

The technology is called "CAPTCHA", or in our case "reCAPTCHA" and is quickly being the standard for online protection against robots, which pose a real problem to web sites. This is replacing the (to me) very irritating practice of trying to figure out what letters and numbers they are showing in fuzzy text. If you have questions or problems getting around the new challenge (or if you are a robot!), feel free to give Joyce a call in the office.

Dale Furseth, "the computer guy"

NOTICES

Gazette PUBLICATION DEADLINE:

Submissions to the Gazette must be received by the 15th of the month of publication. The fifteenth of the month is to be the last day to submit material. Material received after the 15th of the month may be held until the following month or rejected.

SUBMISSION CRITERIA

Articles and ads may be submitted via a pdf file, MS WORD, Open Office, notepad, or similar text file attached to an email. **The email SUBJECT line must include your article title and a date.**

Please give each article a distinct file name with your name and a date. If everyone submits an article named "article for gazette" or something similar it will often get overwritten by another article with the same name when downloading. **Articles sent as text in a email text will no longer be accepted.**

Please use a common open source FONT such as ARIAL that can be displayed in all Browsers, and is easy to read. Please do NOT use the Calibri font, as we must take the time to convert it to Arial.

If your document has an embedded image, you must also include the image separately as a jpg, png, or similar image file.

Visitors to Train Mountain and YOU:

Train Mountain is very popular and is continually attracting visitors from throughout the world. We announce that our hours are from 9:00 AM until 3:00 PM Monday through Friday during the summer, and 10:00 AM to 2:00 PM during the winter. The office is closed on weekends except during meets, and then only when volunteers are available to open the office.

Our insurance advisors request that all people (members and visitors) complete and sign a liability release. If **YOU** as a member encounter visitors on the property without a visitors pass please direct them to the office so that we can insure that a release has been completed and a visitors pass has been issued.

If **YOU**, as a member, open the gate and allow visitors to pass through - **YOU** are responsible to see that the release has been completed, and **YOU** are liable for them until they sign a release. Releases are available in the mailboxes near the office for those times when the office is closed. There are also releases available in the kitchen and in the Back Shop.

If you do not want to, or do not have the time to, ensure that the releases are completed - then please graciously explain that the train park is closed to visitors and that the open hours are normally (Winter - 10:00 AM until 2:00 PM) (Summer - 9:00 AM until 3:00 PM) Monday through

Train Mountain is a NO SMOKING Facility

During recent events, many Members and their Guests have been ignoring this policy. There are only three designated smoking areas at Train Mountain:

- (1) Outside the front of the Backshop
- (2) Outside the east door of the Hall of Flags
- (3) Outside the Motor Pool (Maintenance Building)

Due to the high fire danger at Train Mountain during the summer, we have zero tolerance for anyone smoking outside one of the designated areas.

There is NO SMOKING anywhere out on the track!

Members, Guests, and Visitors that continue to violate the Train Mountain Smoking Policy may be asked to leave.

What is Amazon Smile?

In a nutshell, it is a way for Train Mountain to receive 501c3 donations from Amazon. According to Amazon: AmazonSmile is a simple and automatic way for you to support your favorite charitable organization every time you shop, at no cost to you. When you shop at smile.amazon.com, you'll find the exact same low prices, vast selection and convenient shopping experience as Amazon.com, with the added bonus that Amazon will donate a portion of the purchase price to your favorite charitable organization. You can choose from nearly one million organizations to support.

When you go to Amazon Smile, choose Train Mountain Institute as your charity. In order for this to work, you must always start from Amazon Smile. Then all else is the same, your account, wish lists, etc. Also available is a direct link: <http://smile.amazon.com/ch/27-4031025> for the TMI account.

The AmazonSmile Foundation will donate 0.5% of the purchase price from your eligible AmazonSmile purchases. I found that just about everything I purchased lately is eligible.

If we can get a large number of Train Mountain supporters to take advantage of the Amazon Smile program, this could result in sizable donations to Train Mountain.

[Click here for more information.](#)

New Gate Code

Due to security concerns, the Gate Code for the Train Mountain Main Gate may be changed at any time without notice. Any Member planning to arrive at Train Mountain when the Office is closed will need to contact the Office prior to arrival to ensure they have the current Gate Code.

Get New Gate Code—Call Office 541-783-3030

Train Mountain Volunteer Hours

Name: _____

Month & Year: _____

Date	Project(s) Worked On	Number of Hours
Total Hours		

Volunteer Hours Reporting

Dale Furseth has worked his techie magic on the member's part of our website again. You can now report your monthly volunteer hours online. From the Train Mountain Railroad home page, click on "Online Member Resources: Join Train Mountain: "Register for Meets", then on "Enter Volunteer Hours" or go there directly with this link:

https://trainmtn.org/tmrrmembers/Member_VolunteerHours.aspx

Choose your name from the drop down menu, enter your total hours in the box that matches the month you are reporting your hours for and click on "Update Information" to submit them. So-o-o simple! We hope you enjoy using this feature.